

Electric Motor or Gas Engine must be purchased separately.

# Triplex Direct Drive Plunger Pump

Model

**2SF**

## PUMP FEATURES

- UNIFLOW design provides continuous fluid flow forward through the pump, reduces cavitation risk and increases pump life.
- Triplex design with unique spring loaded inlet valves and the flow through ceramic plungers provides a smooth, steady flow.
- Ultimate portability—less than 11 pounds—less than 10" long.
- Standard shaft pump for direct mounting or special SOLID SHAFT and LOW RPM models.
- Regulating Unloader is standard on each pump to assure system pressure control and pump protection.
- Special Hi-Temp seal option for pumping 190°F water.
- Optional Thermo Valve mounts directly into by-pass hose for optimum heat protection while in by-pass.

## COMMON PUMP SPECIFICATIONS

Inlet Pressure .....	(Standard)	Flooded to 75 PSI	(Flooded to 5.25 BAR)
	(Hi-Temp)	30 to 75 PSI	(2.1 to 5.25 BAR)
Bore.....		0.708"	(18 mm)
Max. Fluid Temperature ..	(Standard)	160°F	(71°C)
	(Hi-Temp)	190°F	(88°C)
Crankcase Capacity .....		11.83 oz.	(.35 L)
Inlet Ports (1).....		3/8" NPT	(3/8" NPT)
Discharge Ports (2) .....		3/8" NPT	(3/8" NPT)
By-Pass Ports (1).....		1/4" NPT	(1/4" NPT)
Weight (Pump Only).....		10.6 lbs.	(4.8 kg)
Dimensions (Pump Only) .....		9.13 x 6.65 x 6.50"	(232 x 169 x 165mm)

Refer to pump Service Manual for important Inlet Condition Check-List, Start-up Procedure, Tech Bulletins and Pump Maintenance information.

## SPECIFICATIONS

	U.S. Measure	Metric Measure	U.S. Measure	Metric Measure
<b>MODEL</b>			<b>2SF10ES</b>	
Volume .....			1.0 GPM	(3.8 L/M)
Max. Discharge Pressure.....			2000 PSI	(140 BAR)
Max. RPM.....			3450 RPM	(3450 RPM)
Stroke .....			0.067"	(1.7 mm)
<b>MODEL</b>			<b>2SF20ES</b>	<b>2SF22ES</b>
Volume .....	2.0 GPM	(7.6 L/M)	2.2 GPM	(8.3 L/M)
Max. Discharge Pressure.....	2000 PSI	(140 BAR)	2000 PSI	(140 BAR)
Max. RPM.....	3450 RPM	(3450 RPM)	3450 RPM	(3450 RPM)
Stroke .....	0.122"	(3.1 mm)	0.132"	(3.35 mm)
<b>MODEL</b>			<b>2SF22ELS</b>	
Volume .....			2.2 GPM	(8.3 L/M)
Max. Discharge Pressure.....			<b>2000 PSI</b>	<b>(140 BAR)</b>
Max. RPM.....			<b>1725 RPM</b>	<b>(1725 RPM)</b>
Stroke .....			0.248"	(6.3 mm)
<b>MODEL</b>			<b>2SF22GS</b>	<b>2SF22SLS</b>
Volume .....	2.2 GPM	(8.3 L/M)	2.2 GPM	(8.3 L/M)
Max. Discharge Pressure.....	2000 PSI	(140 BAR)	2000 PSI	(140 BAR)
Max. RPM.....	3450 RPM	(3450 RPM)	<b>1725 RPM</b>	<b>(1725 RPM)</b>
Stroke .....	0.1323"	(3.35 mm)	0.248"	(6.3 mm)
<b>MODEL</b>			<b>2SF29ELS</b>	<b>2SF30ES</b>
Volume.....	2.85 GPM	(10.8 L/M)	3.0 GPM	(11.4 L/M)
Max. Discharge Pressure.....	<b>1500 PSI</b>	<b>(105 BAR)</b>	1500 PSI	(105 BAR)
Max. RPM.....	<b>1725 RPM</b>	<b>(1725 RPM)</b>	3450 RPM	(3450 RPM)
Stroke .....	0.335"	(8.5 mm)	0.177"	(4.5 mm)
<b>MODEL</b>			<b>2SF30GS</b>	
Volume .....			3.0 GPM	(11.4 L/M)
Max. Discharge Pressure.....			<b>2000 PSI</b>	<b>(140 BAR)</b>
Max. RPM.....			3450 RPM	(3450 RPM)
Stroke.....			0.185"	(4.7 mm)
<b>MODEL</b>			<b>2SF35ES</b>	<b>2SF35GS</b>
Volume.....	3.5 GPM	(13.2 L/M)	3.5 GPM	(13.2 L/M)
Max. Discharge Pressure.....	1500 PSI	(105 BAR)	<b>2000 PSI</b>	<b>(140 BAR)</b>
Max. RPM.....	3450 RPM	(3450 RPM)	3450 RPM	(3450 RPM)
Stroke .....	0.220"	(5.6 mm)	0.220"	(5.6 mm)

Optional Electric-3/4" Shaft - 2SF30GES, 2SF35GES

ES, ELS = **Electric 5/8"** hollow shaft with bolt mount, GES = **Electric 3/4"** hollow shaft with bolt mount, GS = **Gas 3/4"** hollow shaft with bolt and adapter mount, SLS = **Electric 3/4"** solid shaft complete with bracket mount. Add "3" to PN for Hi-Temp version.

*"Customer confidence is our greatest asset"*

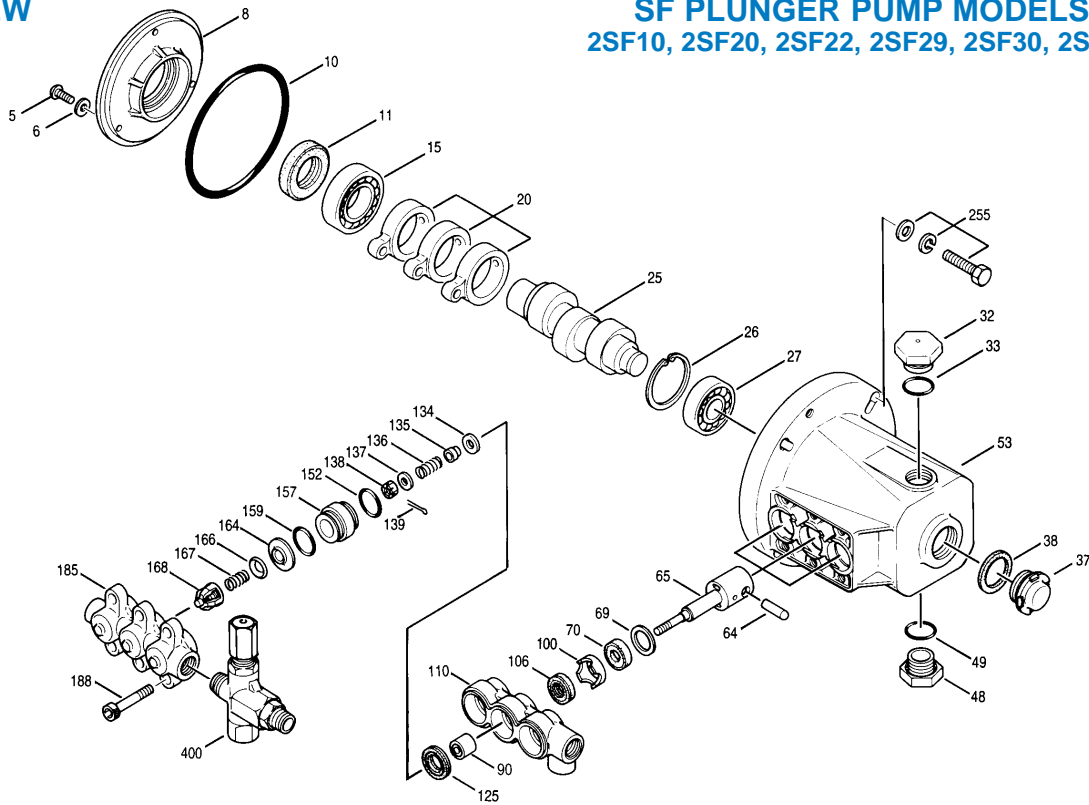

**PARTS LIST**

ITEM	P/N	MATL	DESCRIPTION	MODEL USED	QTY	ITEM	P/N	MATL	DESCRIPTION	MODEL USED	QTY
5	89551	STZP	Screw, HHC (M6 x 16)	All Models	3	134	45854	S	Valve, Inlet	All Models	3
6	150810	NBR	Washer, Seal (M6)	All Models	3	33873	NY	Valve, Inlet, Hi-Temp	All Models	3	
8	44857	AL	Cover, Bearing, Inner	All Models	1	135	44871	S	Spacer	All Models	3
10	14044	NBR	O-Ring, Bearing Cover	All Models	1	136	44872	S	Spring, Inlet Valve	All Models	3
11	44859	NBR	Seal, Oil	All Models	1	137	88575	S	Washer, Conical (M6)	All Models	3
15	14488	STL	Bearing, Ball, Inner	All Models	1	138	27000	S	Nut, Slotted (M6)	All Models	3
20	45876	HS	Rod, Connecting	All Models	3	139	14158	S	Cotterpin	All Models	3
25	543135	FCM	Crankshaft, 3450 RPM, 5/8", 1.7mm	10ES	1	152	26089	NBR	O-Ring, Adapter, Inner - 70	All Models	3
	45092	FCM	Crankshaft, 3450 RPM, 5/8", 3.1mm	20ES	1	11377	FPM	O-Ring, Adapter, Inner	All Models	3	
	44933	FCM	Crankshaft, 3450 RPM, 3/4", 3.35mm	22GS	1	157	44878	BB	Discharge Valve Adapter	All Models except 29ELS	3
	44929	FCM	Crankshaft, 3450 RPM, 5/8", 3.35mm	22ES	1	45430	BB	Discharge Valve Adapter	29ELS	3	
	542441	FCM	Crankshaft, 3450 RPM, 3/4", 4.7mm	30GS	1	159	26089	NBR	O-Ring, Adapter, Outer - 70	All Models	3
	44931	FCM	Crankshaft, 3450 RPM, 5/8", 4.5mm	30ES	1	11377	FPM	O-Ring, Adapter, Inner	All Models	3	
	45096	FCM	Crankshaft, 3450 RPM, 5/8", 5.6mm	35ES	1	164	44881	S	Seat	All Models	3
	45100	FCM	Crankshaft, 3450 RPM, 3/4", 5.6mm	35GS	1	166	43723	S	Valve	All Models	3
	45160	FCM	Crankshaft, 1725 RPM, 5/8", 6.3mm	22ELS	1	167	541062	S	Spring	All Models	3
	45426	FCM	Crankshaft, 1725 RPM, 5/8", 8.5mm	29ELS	1	168	44565	PVDF	Retainer, Spring	All Models	3
	45146	FCM	Crankshaft, 1725 RPM, Solid, 3/4", 6.3mm	22SLS	1	185	44879	BB	Manifold, Discharge	All Models	1
26	12385	STL	Ring, Retaining	All Models	1	188	87859	STZP	Screw, HSH (M8x75)	All Models	6
27	15710	STL	Bearing, Ball, Outer	All Models	1	249	30968		Kit, Adapter Mount, Gas	22G, 30G, 35G	1
32	45690	RTP	Cap, Oil Filler	All Models	1	15845	STZP	Lockwasher, Split (M8)		4	
33	14179	NBR	O-Ring, Oil Filler Cap - 70	All Models	2	44843	STZP	Screw, HH (5/16-24)		4	
37	43987		Gauge, Bubble Oil	All Models	1	44942	AL	Flange		1	
38	44428	NBR	Gasket, Flat Flex., Oil Gauge - 80	All Models	1	12489	STZP	Washer, Flat (M8)		4	
48	44842	NY	Plug, Drain (1/2" NPT)	All Models	1	255	30517	STZP	Kit, Bolt Mount	All Models	1
49	14179	NBR	O-Ring, Drain Plug - 70	All Models	1	30980	STZP	Washer, Flat (3/8")		4	
53	45702	AL	Crankcase	All Models	1	30921	STZP	Lockwasher, Split (3/8")		4	
64	16948	S	Pin, Rist	All Models	3	34100	STZP	Screw, HH (3/8"-16 x 1-3/8")		4	
65	44865	SZZ	Rod, Plunger	All Models except 29ELS	3	6106		Lubricant, Antiseize		1	
	45427	SZZ	Rod, Plunger	29ELS	3	30050	STL	Key (3/16" x 3/16" x 1-1/4" HD)		1	
69	20017	STZP	Washer (M24)	All Models	3	259	30973	STZP	Kit, Mounting Bracket (Incl. w/Pump)	22SL	1
70	25461	NBR	Seal, Oil	All Models	3			(Incl. Bracket, Washers, Bolts, Nuts)			
90	45847	CC	Plunger	All Models except 29ELS	3	300	34053	NBR	Kit, Seal (Incl. 106, 125, 134, 139, 152, 159)	All Models	1
	45429	CC	Plunger	29ELS	3	33953	HT	Kit, Seal - Hi-Temp (Incl. 106, 125, 134, 139, 152, 159)	All Models	1	
100	44869	PVDF	Retainer, Seal	All Models	3	33453	FPM	Kit, Seal (Incl. 106, 125, 134, 139, 152, 159)	All Models	1	
106	44876	NBR	Seal, LPS w/S-Spg	All Models	3	310	34052	S	Kit, Valve (Incl. 152, 159, 164, 166, 167, 168)	All Models	1
	103298	FPM	Seal, LPS w/S-Spg	All Models	3	311	34668	NBR	Kit, Inlet Valve (Incl. 134-139, 152, 159)	All Models	1
110	44874	BB	Manifold, Inlet	All Models	1	352	44050	STZP	Tool, Oil Gauge Removal	All Models	1
125	43245	NBR	Seal, HPS w/S	All Models	3	400	7500S	BB	Unloader, Regulating	All Models	1
	46652	HT	Seal, Hi-Temp (190° Max)	All Models	3	34455	BB	Assembly, Pulsator	All Models	1	
						6565.8		Service Video, Section 8	All Models	1	

● Industrial discount. **Bold print part numbers are unique to a particular pump model.** *Italics are optional items.* See Tech Bulletins 43, 55, 60, 64, 65, 70, 73 and 74 for additional information.  
NOTE: Discard Key which may come standard with most motors and engines and **use only the key included in this kit.** Add "3" to Part Number for special 190°F Hi-Temp seals.

MATERIAL CODES (Not Part of Part Number): AL=Aluminum BB=Brass CC=Ceramic FCM=Forged Chrome-moly FPM=Fluorocarbon (Viton®)  
HS=High Strength HT=Hi-Temp (EPDM Alternative) NBR=Medium Nitrile (Buna-N) NY=Nylon PVDF=Fluoroplastic (High Strength) RTP=Reinforced Composite  
S=304SS STL=Steel STZP=Steel/Zinc Plated SZZ=304SS/Zamak ZZ=Zamak

Center raised pilot guide on the **Adapter Plate** assures proper alignment of pump and engine. Before mounting pump onto engine inspect engine for **recessed seal and bearing guide** to permit adapter to completely seat into recess and four bosses to be flush with engine face.

## UNLOADER SPECIFICATIONS

MODEL 7500S	U.S. Measure	Metric Measure
GPM .....	0.5-6.0 GPM	(2-23 L/M)
PSI .....	100-2000 PSI	(7-140 BAR)
Inlet Port - Rear .....	3/8" NPT	(3/8" NPT)
Discharge Port - Front .....	M18 x 1.0	(M18 x 1.0)
By-pass Port - Bottom .....	3/8" NPT	(3/8" NPT)
Weight .....	14 oz.	(0.43 kg)
Dimensions .....	3.0" x 1.0" x 4.25"	(76 x 25 x 108mm)

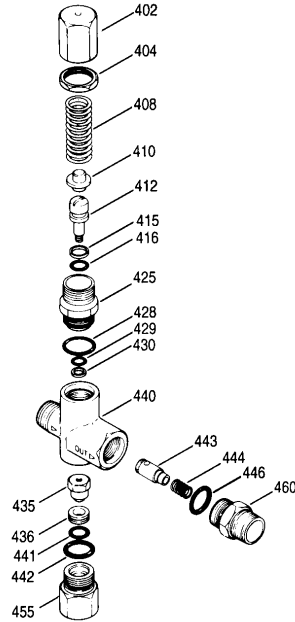

ITEM	P/N	MATL	DESCRIPTION	QTY.
402	540081	BB	Cap, Hex Adjusting	1
404	31047	BB	Nut, Locking (M18x1)	1
408	32094	STZP	Spring, Coil	1
410	107672	BB	Retainer, Spring	1
412	45694	S	Stem, Piston (M5)	1
415	20184	PTFE	Back-up-Ring, Piston Stem	1
416	14190	NBR	O-Ring, Piston Stem	1
425	107673	BB	Retainer, Piston	1
428	13969	NBR	O-Ring, Piston Retainer - 70	1
429	14759	NBR	O-Ring, Body	1
430	107675	PTFE	Back-up-Ring, Body	1
435	45696	BB	Valve and Ball Assembly (M5)	1
436	107680	S	Seat	1
440	—	BB	Body	1
441	13963	NBR	O-Ring, Valve	1
442	13969	NBR	O-Ring, By-Pass Fitting - 70	1
443	541060	BB	Valve, Check w/O-Ring	1
444	45924	S	Spring - 85G	1
446	13969	NBR	O-Ring, Discharge Fitting - 70	1
455	45695	BB	Fitting, By-Pass (3/8" NPT)	1
460	107681	BB	Fitting, Discharge (3/8" NPT)	1
465	7090	—	By-Pass Hose (15" x 3/8") 160°F	1
466	7090.40	—	By-Pass Hose w/Thermo Valve	1
468	32097	NBR	Kit, O-Ring (Incls: 415, 416, 428, 429, 430, 441, 442, 446)	1
485	7140	BB	Valve, Thermo	1
486	34600	BB	Tee, T.V. Mount	1
487	34576	BB	Nipple, T.V. Mount	1

*Italics are optional items.*

MATERIAL CODES (Not Part of Part Number): BB=Brass NBR=Medium Nitrile (Buna-N)  
PTFE=Polytetrafluoroethylene (Teflon®) S=304SS STZP=Steel/Zinc Plated

## OPERATION

A Regulating Unloader comes with each 2SF pump to provide system pressure regulation and pump protection. For suction feed consult factory.

By-pass for the regulating unloader may drain to the ground, drain to a reservoir or connect to the special 1/4" by-pass port on the underside of the inlet manifold. A 3/8" flexible hose and Thermo Valve (7090.40) are recommended. **DO NOT EXCEED 6 MINUTES in BY-PASS when Thermo Valve is not installed.**

**Hi-Temp Units** with special Hi-Temp seals do not use the by-pass hose back to the pump inlet or the Thermo Valve. Use optional Dual Pressure Switches and Mechanical Relay in Auto Shut Off Kits 34870 and 34871.

If unit is INFREQUENTLY USED OR PERIODICALLY STORED, seals may become dry. System should be PURGED BEFORE OPERATION (system fluid must flow through the pump without discharge restriction) to assure full system pressure is reached.

## CHEMICAL INJECTOR SPECIFICATIONS

MODEL	Standard 7193	Optional 7194
Flow .....	3-4 GPM	4-5 GPM
Nozzle Orifice .....	2.1mm	2.3mm
Hose Barb .....	1/4"	1/4"
Inlet Port .....	M18 x 1.0	M18 x 1.0
Discharge Port .....	3/8" NPTM	3/8" NPTM
Weight .....	6.3 oz.	6.3 oz.
Dimensions .....	2" x 1" x 3"	2" x 1" x 3"

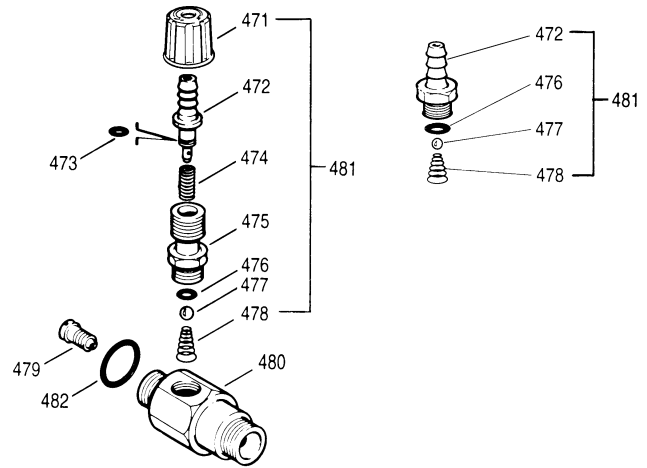

ITEM	P/N	MATL	DESCRIPTION	QTY.
471	33949	BBNY	Cap, Adjustment	1
472	32941	BB	Hose Barb	1
473	33503	NBR	O-Ring, Hose Barb	1
474	33500	S	Spring	1
475	38946	BB	Retainer, Ball Seat	1
476	33504	FPM	O-Ring, Retainer	1
477	34620	SS	Ball	1
478	33501	SS	Spring, Tapered	1
479	32373	S	Orifice, Injector (2.1mm) Standard	1
—	32374	S	Orifice, Injector (2.3mm)	1
480	—	BB	Body	1
481	33481	BB	Barb, Assy, Adjustable (Incls: 471, 472, 473, 474, 475, 476, 477, 478)	1
—	33480	BB	Barb, Assy, Fixed (Incls: 472, 476, 477, 478)	1
482	13969	NBR	O-Ring, Body - 70	1

*Italics are optional items.*

MATERIAL CODES (Not Part of Part Number): BB=Brass FPM=Fluorocarbon (Viton®)  
NBR=Medium Nitrile (Buna-N) NY=Nylon S=304SS SS=316SS

CHEMICAL INJECTOR PERFORMANCE CHART				
Optional Special Ported Chemical Injector for Unloader Mounting				
Standard Pump Model	Injector Orifice Size	Lo-Pressure Nozzle Rating (Maximum Downstream) (Press for Injector)	Max. Chem. Draw (0 PSI) (Downstream)	Hi-Press Nozzle "Deduction" (Press. drop across Inj.)
2SF20	2.1 mm (7193)	100 PSI	50 oz/min	100 PSI
2SF22	2.1 mm (7193)	75 PSI	50 oz/min	100 PSI
2SF29, 2SF30	2.1 mm (7193)	225 PSI	50 oz/min	150 PSI
2SF35	2.3 mm (7194)	150 PSI	50 oz/min	150 PSI

Optimum performance of chemical injector occurs with a **35 ft. high pressure hose** and a minimum 3/8" I.D. The type of hose, extended lengths, reduced I.D. and fittings may create **back pressures** in excess of the low pressure nozzle rating and **prevent the injector** from drawing chemical. **Deduct hose friction loss from above low PSI Nozzle. Contact factory for assistance with other options.** Refer to Hose Friction Loss Chart in the High Pressure Guide for pressure loss with longer hose.

An optional, **specially ported chemical injector** may be mounted directly to the discharge of the unloader. Remove o-ring, check valve and spring from discharge fitting of unloader; insert into injector and thread into unloader discharge port. **Discard o-ring and discharge fitting.** Refer to the performance chart to determine the orifice size best suited to the system flow. **Chemical draw occurs under low pressure.** Select the Dual Nozzle (32149), Adjustable Nozzle (32151), or Vari-Nozzle (7930-7980) to permit the adjustment from low to high pressure.

For optimum performance when using a chemical injector, use a **single wire braid hose** on the discharge line. Too flexible a hose will prevent the unloader from receiving the full pressure signal to activate the by-pass mode.

For correct nozzle selection, **read system pressure at the pump. DO NOT READ SYSTEM PRESSURE AT THE HIGH PRESSURE GUN.** Incorrect pressure reading may result in: pump operation at excessive pressures, inconsistent chemical draw, or possible damage to the pump or unloader.

# MOTOR SPECIFICATIONS

**Model 8050**

Horsepower .....	1.5
Shaft Diameter.....	5/8"
Max. Volts.....	115
FULL LOAD AMPS.....	12.1
RPM.....	3450
Weight.....	48 lbs.
Phase.....	Single
Frame Size.....	56-C TEFC
Service Factor.....	1.15

**Model 8052**

Horsepower .....	2.0
Shaft Diameter.....	5/8"
Max. Volts.....	115/230
FULL LOAD AMPS.....	17.0/9.2-8.5
RPM.....	3450
Weight.....	43 lbs.
Phase.....	Single
Frame Size.....	56-C TEFC
Hertz.....	60
Service Factor.....	1.15

**Model 8055**

Horsepower .....	3.0
Shaft Diameter.....	● 3/4"
Max. Volts.....	208/230
FULL LOAD AMPS.....	15.2/13.6
RPM.....	3450
Weight.....	48 lbs.
Phase.....	Single
Frame Size.....	56-C TEFC
Service Factor.....	1.15

**Model 8057**

Horsepower .....	5.0
Shaft Diameter.....	● 3/4"
Max. Volts.....	230
FULL LOAD AMPS.....	22.0
RPM.....	3450
Weight.....	48 lbs.
Phase.....	Single
Frame Size.....	56-C OPEN DRIP
Service Factor.....	1.15

**\* Model 8060**

Horsepower .....	1.5
Shaft Diameter.....	5/8"
Max. Volts.....	115/208/230
FULL LOAD AMPS.....	14.0/7.0
RPM.....	1725
Weight.....	48.10 lbs.
Phase.....	Single
Frame Size.....	56-C TEFC
Service Factor.....	1.2

**\* Model 8062**

Horsepower .....	2.0
Shaft Diameter.....	5/8"
Max. Volts.....	115/230
FULL LOAD AMPS.....	17.0/8.5
RPM.....	1725
Weight.....	55 lbs.
Phase.....	Single
Frame Size.....	56-C TEFC
Service Factor.....	1.15

**Common Motor Specifications**

Max. Operating Temp.....	104°F
Capacitor Start .....	Yes
Thermal Overload-Manual Reset .....	Yes
U.L. Construction Reference .....	
(8050,8055).....	E49747
(8052, 8057, 8060, 8062) .....	E44549
U.L. Insulation Reference (All) ...	E37878
CSA Reference .....	
(8050) .....	LR45148
(8052, 8057, 8060, 8062).....	LR4642
(8055) .....	LR2025

Note: Motor Start-Up AMPS may vary, then settle within FULL LOAD AMPS rating after initial run in time.

★ ★ Before mounting pump on motor, apply P.N. 6106 Antiseize Lubricant to pump shaft.

★ ★ Refer to Tech Bulletin #55 for instructions on removing pump from gas engine or electric motor.

Add .50 for 50 Hz (1450 or 2850 RPM)

For warranty consideration contact CAT PUMPS for the local **Authorized Service Center**. If you are uncertain as to the cause of failure (Pump or Motor), secure **Returned Goods Authorization number** and return complete assembly **PREPAID** to CAT PUMPS for evaluation.

## HORSEPOWER REQUIREMENTS

FLOW		PRESSURE					PUMP RPM
		PSI 700	PSI 1000	PSI 1200	PSI 1500	PSI 2000	
U.S. GPM	Metric L/M	BAR 50	BAR 70	BAR 85	BAR 105	BAR 140	
1.0	3.8	.44	.69	.82	1.0	1.4	3450
2.2	8.3	1.1	1.5	1.8	2.3	3.0	3450
2.85	10.8	1.4	2.0	2.3	2.9	N/A	1725
3.0	11.4	1.4	2.1	2.5	3.1	4.2	3450
3.5	13.2	1.7	2.4	2.9	3.6	N/A	3450

## DETERMINING THE REQUIRED H.P.

$$\frac{\text{GPM} \times \text{PSI}}{1460} = \text{Electric Brake H.P. Required}$$

## DIMENSIONAL DRAWING

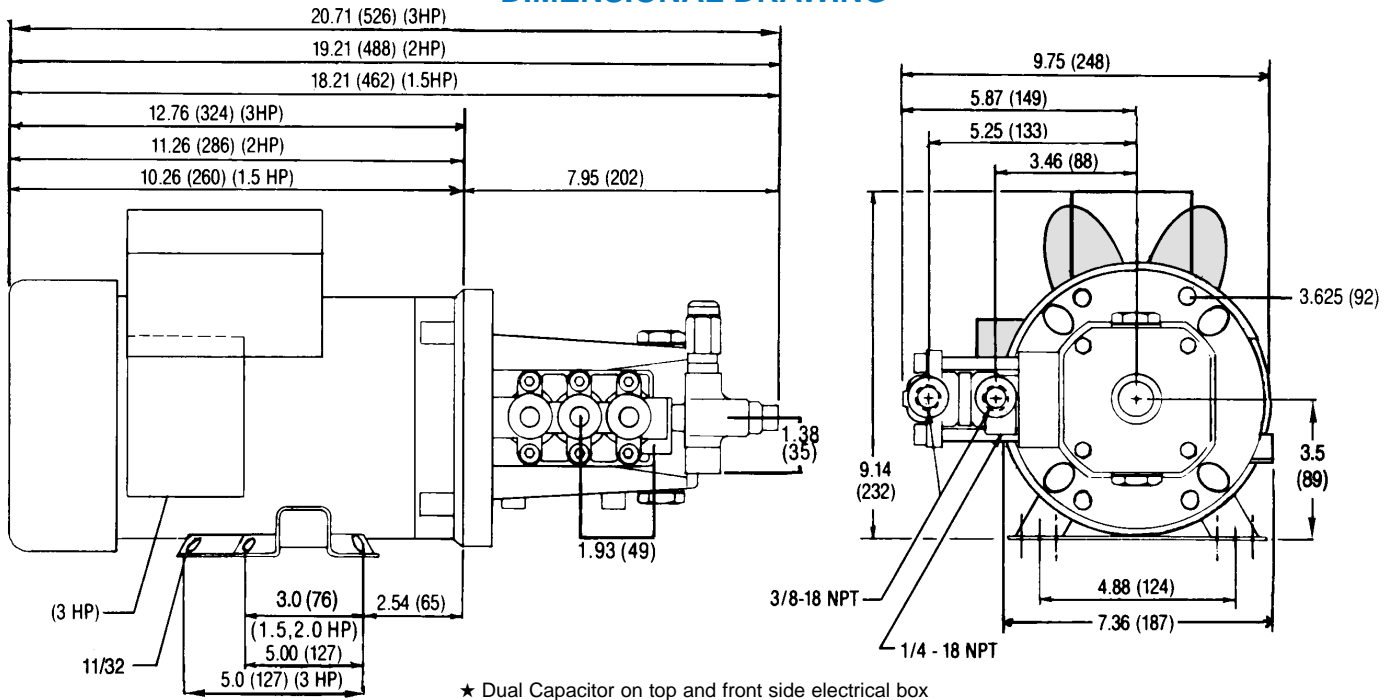

Products described hereon are covered by one or more of the following U.S. patents 3558244, 3652188, 3809508, 3920356, 3930756 and 5035580

May 1999 5902

### World Headquarters

CAT PUMPS

1681 - 94th Lane N.E. Minneapolis, MN 55449-4324

Phone (612) 780-5440 — FAX (612) 780-2958

e-mail: sales@catpumps.com

www.catpumps.com

### International Inquiries

FAX (612) 785-4329

e-mail: intlsales@catpumps.com



The Pump with "Nine Lives"

### CAT PUMPS (U.K.) LTD.

1 Fleet Business Park, Sandy Lane, Church Crookham, Fleet

Hampshire GU13 0BF, England

Phone Fleet 44 1252-622031 — Fax 44 1252-626655

### N.V. CAT PUMPS INTERNATIONAL S.A.

Heiveldekens 6A, 2550 Kontich, Belgium

Phone 32-3-450.71.50 — Fax 32-3-450.71.51

e-mail: cpi@catpumps.be

### CAT PUMPS DEUTSCHLAND GmbH

Buchwiese 2, D-65510 Idstein, Germany

Phone 49 6126-93030 — Fax 49 6126-930333

e-mail: catpumps@t-online.de www.catpumps.de