

Nickel Aluminum Bronze Direct-Drive Plunger Pump

Models 2SF10CEE
2SF20CEE
2SF29CEEL

PUMP FEATURES

- UNIFLOW design provides continuous fluid flow forward through the pump, reduces cavitation risk and increases pump life.
- Unique spring loaded Inlet Valves and flow through ceramic plungers assure smooth, consistent fluid flow through pump.
- Nickel Aluminum Bronze Head for strength and corrosion resistance.
- OPTIONAL Stainless Steel Regulator for system pressure control and pump protection.
- Ultimate portability: weighs less than 11 pounds and is only 10 inches long.
- OPTIONAL 3450 or 1725 RPM direct-drive motors for ultra compact assembly.

SPECIFICATIONS

	U.S. Measure	Metric Measure
MODEL 2SF10CEE		
Flow.....	1.0 GPM	(3.8 L/M)
Discharge Pressure.....	100 to 1200 PSI	(7 to 85 BAR)
RPM	3450 RPM	(3450 RPM)
Stroke.....	0.067"	(1.7 mm)
MODEL 2SF20CEE		
Flow.....	2.0 GPM	(7.6 L/M)
Discharge Pressure.....	100 to 1200 PSI	(7 to 85 BAR)
RPM	3450 RPM	(3450 RPM)
Stroke.....	0.122"	(3.1 mm)
MODEL 2SF29CEEL		
Flow.....	2.85 GPM	(10.8 L/M)
Discharge Pressure.....	100 to 1500 PSI	(7 to 105 BAR)
RPM	1725 RPM	(1725 RPM)
Stroke.....	0.335"	(8.5 mm)

COMMON SPECIFICATIONS

Inlet Pressure	Flooded to 60 PSI	(Flooded to 4 BAR)
Shaft Diameter	5/8"	(15.9 mm)
Bore.....	0.709"	(18 mm)
Max. Fluid Temperature.....	160° F	(71° C)
Crankcase Capacity	12.0 oz.	(0.36 L)
Inlet Port (1).....	3/8" NPTF	(3/8" NPTF)
Outlet Ports (2)	3/8" NPTF	(3/8" NPTF)
By-Pass Port (1)	1/4" NPTF	(1/4" NPTF)
Weight.....	10.6 lbs.	(4.8 kg)
Dimensions.....	8.3" x 7.5" x 6.3"	(213 x 191 x 160 mm)

Refer to pump Service Manual for important Inlet Condition Check-List, Start-up Procedure, Tech Bulletins and Pump Maintenance information.

“Customer confidence is our greatest asset”

EXPLODED VIEW

October 1998

SF PLUNGER PUMP MODELS

2SF10CEE, 2SF20CEE, 2SF29CEEL

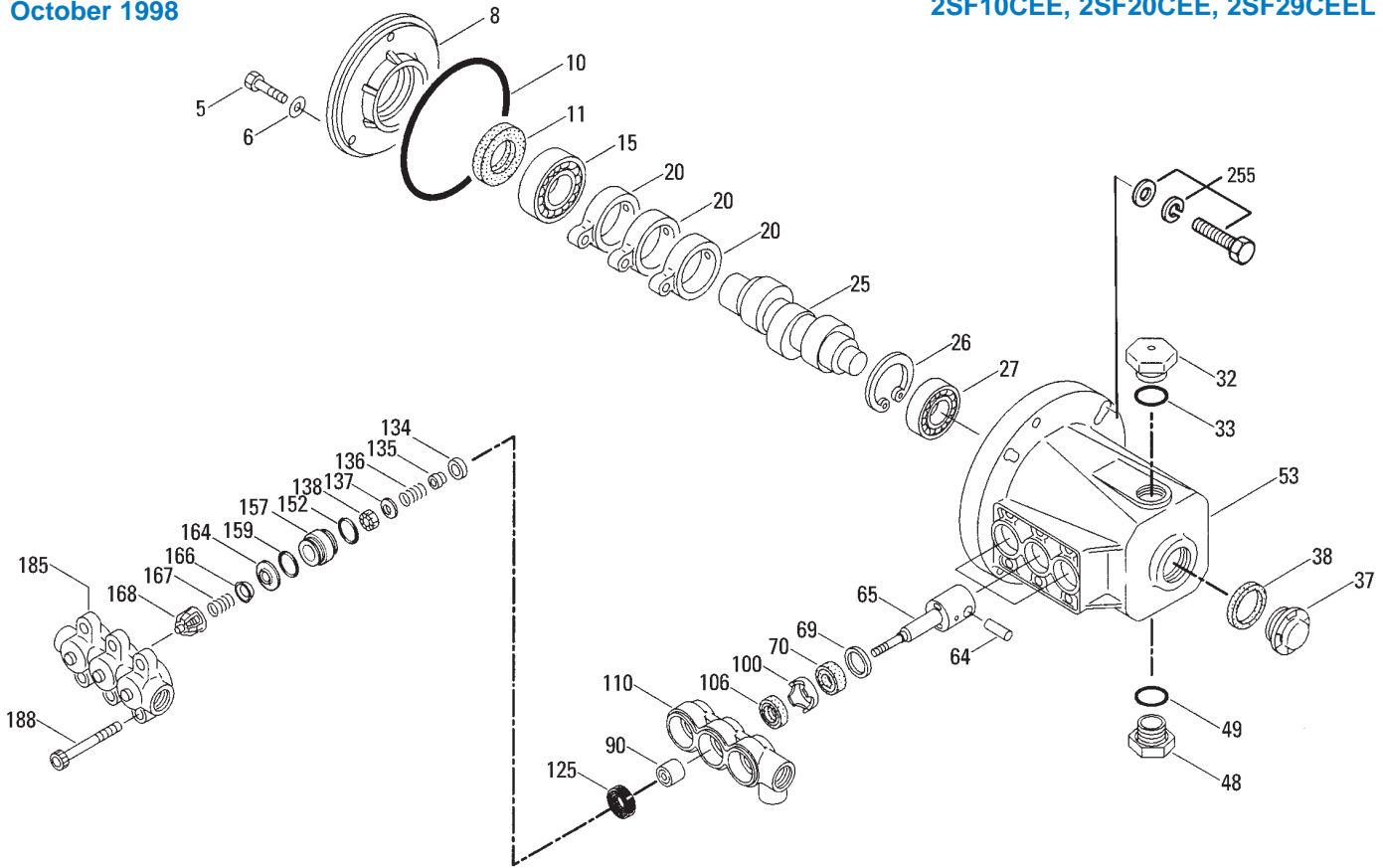

PARTS LIST

ITEM	P/N	MATL	DESCRIPTION	QTY	ITEM	P/N	MATL	DESCRIPTION	QTY
5	543686	S	Screw, HHC (M6x16)	3	134	543691	SS	Valve, Inlet	3
6	150810	NBR	Washer, Seal (M6)	3	135	543689	SS	Spacer	3
8	44857	AL	Cover, Bearing, Inner	1	136	543690	SS	Spring, Inlet Valve	3
10	14044	NBR	O-Ring, Bearing Cover - 70	1	137	88575	S	Washer, Conical (M6)	3
11	44859	NBR	Seal, Oil - 70	1	138	543692	SS	Nut (M6)	3
15	14488	STL	Bearing, Ball, Inner	1	152	26089	NBR	O-Ring, Adapter, Inner - 80	3
20	45876	HS	Rod, Connecting	3	157	544292	SS	Adapter (10CEE, 20CEE)	3
25	543135	FCM	Crankshaft, 3450 RPM, 5/8", 1.7mm (10CEE)	1	544300	SS	Adapter (29CEEL)	3	
	45092	FCM	Crankshaft, 3450 RPM, 5/8", 3.1mm (20CEE)	1	159	26089	NBR	O-Ring, Adapter, Outer - 80	3
	45426	FCM	Crankshaft, 1725 RPM, 5/8", 8.5mm (29CEEL)	1	164	544293	SS	Seat	3
26	12385	STL	Ring, Retaining	1	166	543669	SS	Valve	3
27	15710	STL	Bearing, Ball, Outer	1	167	543700	SS	Spring	3
32	45690	RTP	Cap, Oil Filler	1	168	44565	PVDF	Retainer, Spring	3
33	14179	NBR	O-Ring, Oil Filler Cap - 70	2	185	543642	NAB	Manifold, Discharge	1
37	43987		Gauge, Bubble Oil	1	188	543701	SS	Screw, HSH (M8x75)	6
38	44428	NBR	Gasket, Flat Flex., Oil Gauge - 80	1	255	30517	STZP	Kit, Bolt Mount	1
48	44842	NY	Plug, Drain (1/2" NPT)	1	30980	STZP	Washer, Flat (3/8")	4	
49	14179	NBR	O-Ring, Drain Plug - 70	1	30921	STZP	Lockwasher, Split (3/8")	4	
53	45702	AL	Crankcase	1	34100	STZP	Screw, HH (3/8"-16x1-3/8")	4	
64	16948	S	Pin, Rist	3	6106		Lubricant, Antiseize	1	
65	543687	SS	Rod, Plunger (10CEE, 20CEE)	3	30050	STL	Key (3/16"x3/16"x1-1/4" HD)	1	
	544299	SS	Rod Plunger (29CEEL)	3	300	34973	NBR	Kit, Seal (Incls: 106, 125, 152, 159)	1
69	20017	STZP	Washer (M24)	3	310	34972	SS	Kit, Valve (Incls: 152, 157, 159, 164, 166, 167, 168)	1
70	25461	NBR	Seal, Oil - 80	3	311	34974	NBR	Kit, Inlet Valve (Incls: 134-138, 152, 159)	1
90	45847	CC	Plunger (10CEE, 20CEE)	3	352	44050	STZP	Tool, Oil Gauge Removal	1
	45429	CC	Plunger (29CEEL)	3	400	7070	SS	Pressure Regulator	1
100	44869	PVDF	Retainer, Seal	3		7072	SS	Pressure Regulator	1
106	543693	NBR	Seal, LPS w/S-Spg - 85	3		7077	SS	Pressure Regulator	1
110	543640	NAB	Manifold, Inlet	1	—	6565.8		Service Video, Section 8	1
125	44652	NBR	Seal, HPS w/SS	3					

Italics are optional items. See Tech Bulletins 43, 55, 60, 64, 65, 70, 73 and 74 for additional information.

NOTE: Discard Key which may come standard with most motors and engines and **use only the key included in this kit.**

MATERIAL CODES (Not Part of Part Number): AL=Aluminum CC=Ceramic FCM=Forged Chrome-moly NAB=Nickel Aluminum Bronze

NBR=Medium Nitrile (Buna-N) NY=Nylon PVDF=Fluoroplastic (High Strength) RTP=Reinforced Composite

S=304SS SS=316SS STL=Steel STZP=Steel/Zinc Plated SZZ=304SS/Zamak

OPTIONAL PRESSURE REGULATOR/RELIEF VALVE

Models 7070, 7077

SPECIFICATIONS

U.S. Measure Metric Measure

MODEL 7070

Flow Range.....1.0-12.0 GPM (3.8-45 L/M)
 Pressure Range600-1000 PSI (40-70 BAR)

MODEL 7077

Flow Range.....1.0-4.0 GPM (3.8-15 L/M)
 Pressure Range50-500 PSI (3.5-35 BAR)

COMMON SPECIFICATIONS

Maximum Temperature180°F (82°C)
 Inlet Port1/4" NPTF (1/4" NPTF)
 By-Pass Port.....3/8" NPTF (3/8" NPTF)
 Weight.....1.2 lbs. (0.55 kg)
 Dimensions6.2" x 2.5" (158 x 64 mm)

OPERATION

This pump does not come standard with a regulating device. Determine the system pressure and flow and select one of the above pressure regulators to provide system pressure regulation and pump protection.

This pump is designed for use in saltwater reverse osmosis systems. A fresh water flush is recommended prior to any dormant cycle to avoid stagnant water sitting in pump and premature wear. High PPM may require 316SS construction for optimum pump life.

TORQUE CHART

Pump Item	Thread	Tool Size [Part No.]	Torque		
			in. lbs.	ft. lbs.	Nm
Outer Bearing Case Screw	M6	M10 Hex/Phil. [25082]	50	4.0	6
Inner Bearing Case Screw	M6	M10 Hex/Phil. [25082]	50	4.0	6
Manifold Screw	M8	M6 Allen [30941]	115	9.4	13
Plunger Rod Nut	M6	M10 Hex [25082]	55	4.4	6.2
Bubble Oil Gauge	M28	Oil Gauge Tool [44050]	45	3.6	5

EXPLODED VIEW

Models 7070, 7077

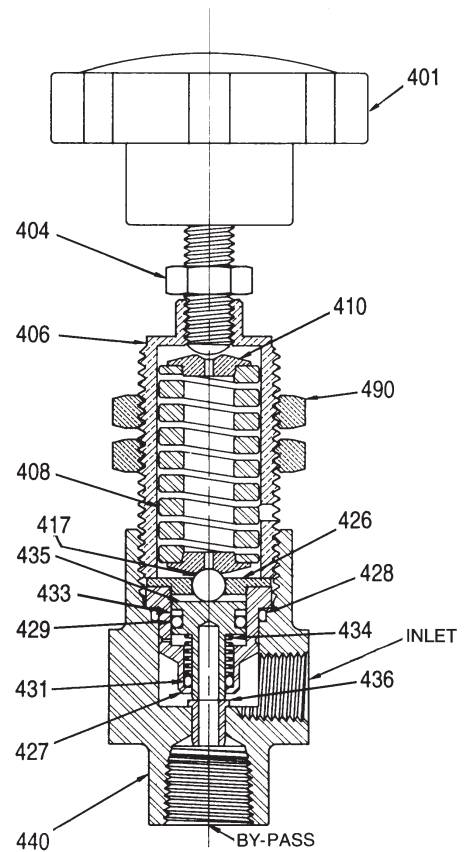

PARTS LIST

ITEM	PN	MATL	DESCRIPTION	QTY
401	33963	NYSS	Knob, Adjusting w/Screw (7070)	1
	34295	NYSS	Knob, Adjusting w/Screw (7077)	1
404	30933	S	Nut, Lock	1
406	—	BBCP	Body, Upper	1
408	32106	S	Spring - 1000 PSI (7070)	1
	34293	S	Spring - 500 PSI (7077)	1
410	—	BB	Retainer	2
417	34001	SSSS	Ball	1
426	—	BB	Guide	1
427	—	SS	Insert	1
428	—	FPM	O-Ring	1
429	—	FPM	O-Ring	1
431	—	FPM	O-Ring	1
433	—	PTFE	Back-up-Ring	1
434	34012	S	Spring	1
435	32109	SS	Piston	1
436	32102	SS	Seat	1
440	—	SS	Body, Lower	1
468	32140	FPM	Kit, O-Ring (Incls: 428, 429, 431, 433)	1
490	34090	STL	Mount, Panel	1

Italics are optional items.

MATERIAL CODES (Not Part of Part Number): BB=Brass
 BBCP=Brass/Chrome Plated FPM=Fluorocarbon (Viton®) NY=Nylon
 PTFE=Polytetrafluoroethylene (Teflon®) S=304 Stainless SS=316 Stainless
 SSSS=440 Stainless STL=Steel

MOTOR SPECIFICATIONS

Model 8050

Horsepower	1.5
Shaft Diameter	5/8"
Max. Volts	115
FULL LOAD AMPS	12.1
RPM	3450
Weight	48 lbs.
Phase	Single
Frame Size	56-C TEFC
Service Factor	1.15

Model 8052

Horsepower	2.0
Shaft Diameter	5/8"
Max. Volts	115/230
FULL LOAD AMPS	17.0/9.2-8.5
RPM	3450
Weight	43 lbs.
Phase	Single
Frame Size	56-C TEFC
Hertz	60
Service Factor	1.15

* Model 8060

Horsepower	1.5
Shaft Diameter	5/8"
Max. Volts	115/208/230
FULL LOAD AMPS	14.0/7.0
RPM	1725
Weight	48.10 lbs.
Phase	Single
Frame Size	56-C TEFC
Service Factor	1.2

* Use with 2SF10CEE or 2SF20CEE to reduce flow by 50%

* Model 8062

Horsepower	2.0
Shaft Diameter	5/8"
Max. Volts	115/230
FULL LOAD AMPS	17.0/8.5
RPM	1725
Weight	55 lbs.
Phase	Single
Frame Size	56-C TEFC
Service Factor	1.15

* Use with 2SF10CEE or 2SF20CEE to reduce flow by 50%

Common Motor Specifications

Max. Operating Temp.	104°F
Capacitor Start	Yes
Thermal Overload-Manual Reset	Yes
U.L. Construction Reference	
(8050)	E49747
(8052, 8060, 8062)	E44549
U.L. Insulation Reference (All)	E37878
CSA Reference	
(8050)	LR45148
(8052, 8060, 8062)	LR4642

Note: Motor Start-Up AMPS may vary, then settle within FULL LOAD AMPS rating after initial run in time.

★ ★ Before mounting pump on motor, apply P.N. 6106

Antiseize Lubricant to pump shaft.

★ ★ Refer to Tech Bulletin #55 for instructions on removing pump from gas engine or electric motor.

Add .50 for 50 Hz (1450 or 2850 RPM)

For warranty consideration contact CAT PUMPS for the local **Authorized Service Center**. If you are uncertain as to the cause of failure (Pump or Motor), secure **Returned Goods Authorization number** and return complete assembly **PREPAID** to CAT PUMPS for evaluation.

HORSEPOWER REQUIREMENTS

FLOW		PRESSURE			PUMP RPM
		PSI 700	PSI 1000	PSI 1200	
U.S. GPM	Metric L/M	BAR 50	BAR 70	BAR 85	
1.0	3.78	.47	.68	.82	3450
2.0	7.56	.95	1.37	1.64	3450
2.85	10.8	1.36	2.0	2.3	1725

DETERMINING THE REQUIRED H.P.

$$\frac{\text{GPM} \times \text{PSI}}{1460} = \text{Electric Brake H.P. Required}$$

2SF10CEE, 2SF20CEE, 2SF29CEEL DIMENSIONAL

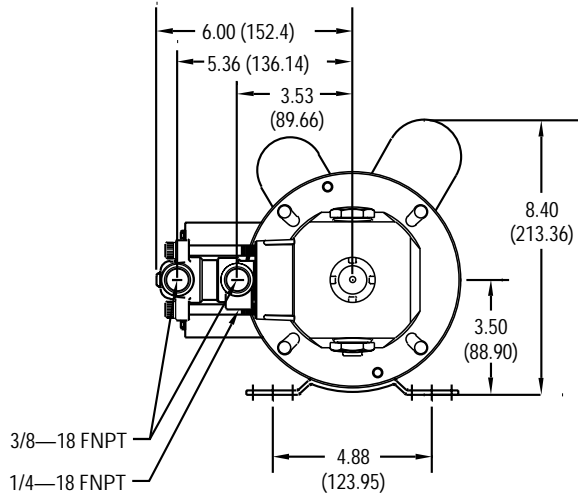
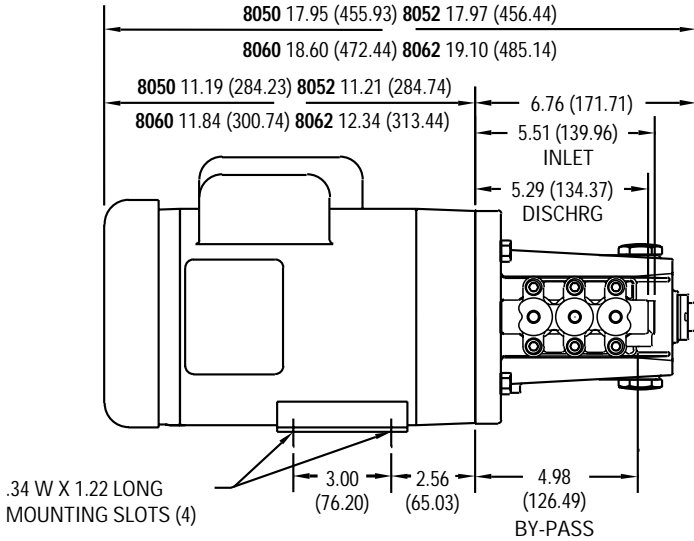

Products described hereon are covered by one or more of the following U.S. patents 3558244, 3652188, 3809508, 3920356, 3930756 and 5035580

Oct 1998 10855

World Headquarters

CAT PUMPS

1681 - 94th Lane N.E. Minneapolis, MN 55449-4324

Phone (612) 780-5440 — FAX (612) 780-2958

e-mail: sales@catpumps.com

www.catpumps.com

International Inquiries

FAX (612) 785-4443

e-mail: intlsales@catpumps.com



The Pump with "Nine Lives"

CAT PUMPS (U.K.) LTD.

1 Fleet Business Park, Sandy Lane, Church Crookham, Fleet

Hampshire GU13 0BF, England

Phone Fleet 44 1252-622031 — Fax 44 1252-626655

N.V. CAT PUMPS INTERNATIONAL S.A.

Heiveldekens 6A, 2550 Kontich, Belgium

Phone 32-3-450.71.50 — Fax 32-3-450.71.51

e-mail: cpi@catpumps.be

CAT PUMPS DEUTSCHLAND GmbH

Buchwiese 2, D-65510 Idstein, Germany

Phone 49 6126-93030 — Fax 49 6126-930333

e-mail: catpumps@t-online.de