

Electric Motor or Gas Engine must be purchased separately.

PUMP FEATURES

- UNIFLOW design provides continuous fluid flow forward through the pump, reduces cavitation risk and increases pump life.
- Ultimate portability—less than 12 pounds—less than 10" long.
- Your choice of Motorized unit or Hollow shaft pump only for direct mounting to gas or electric motor.
- Regulating Unloader with By-pass Hose is standard on each 2SFX pump to assure system pressure control and pump protection.
- Optional Thermo Valve mounts directly into by-pass hose for optimum heat protection while in by-pass.

COMMON PUMP SPECIFICATIONS

Max. Inlet Pressure.....	Flooded to 75 PSI	(Flooded to 5.25 BAR)
Bore	0.708"	(18 mm)
Max. Fluid Temperature	160°F	(71°C)
Crankcase Capacity.....	11.83 oz.	(.35 L)
Inlet Ports (1)	3/8" NPT	(3/8" NPT)
Discharge Ports (2).....	3/8" NPT	(3/8" NPT)
By-pass Port	1/4" NPT	(1/4" NPT)
Weight (Pump Only)	11.83 lbs.	(4.8 kg)
Dimensions (Pump Only).....	9.13 x 6.65 x 6.50"	(232 x169 x165mm)

E = **Electric 5/8"** hollow shaft with bolt mount
 GE, GES = **Electric 3/4"** hollow shaft with bolt mount
 G, GZ = **Gas 3/4"** hollow shaft with bolt mount and adapter
 Add "3" to Part Number for Hi-Temp version

After prolonged storage, pump should be purged of air to facilitate priming.
 Disconnect any discharge port and allow fluid to pass through pump.

Refer to pump Service Manual for important Inlet Condition Check-List, Start-up Procedure, Tech Bulletins and Pump Maintenance information.

Direct-Drive Plunger Pump

Model **2SFX**

SPECIFICATIONS

	U.S. Measure	Metric Measure	U.S. Measure	Metric Measure
MODEL	2SFX20ES		2SFX22ES	
Volume	2.0 GPM	(7.6 L/M)	2.2 GPM	(8.3 L/M)
Max. Discharge Pressure	2000 PSI	(140 BAR)	2000 PSI	(140 BAR)
Max. RPM	3450 RPM	(3450 RPM)	3450 RPM	(3450 RPM)
Stroke.....	0.122"	(3.1 mm)	0.132"	(3.35 mm)

MODEL	2SFX22GS			
Volume.....	2.2 GPM		(8.3 L/M)	
Max. Discharge Pressure	2000 PSI		(140 BAR)	
Max. RPM.....	3450 RPM		(3450 RPM)	
Stroke	0.132"		(3.35 mm)	

Optional Electric-3/4" Shaft - 2SFX22GES

MODEL	2SFX25ES		2SFX25GZ	
Volume	2.5 GPM	(9.5 L/M)	2.5 GPM	(9.5 L/M)
Max. Discharge Pressure	2000 PSI	(140 BAR)	2500 PSI	(175 BAR)
Max. RPM	3450 RPM	(3450 RPM)	3200 RPM	(3200 RPM)
Stroke.....	0.150"	(3.8 mm)	0.169"	(4.3 mm)

MODEL	2SFX29ELS			
Volume	2.85 GPM		(10.8 L/M)	
Max. Discharge Pressure.....	1500 PSI		(105 BAR)	
Max. RPM	1725 RPM		(1725 RPM)	
Stroke.....	.335"		(8.5 mm)	

MODEL	2SFX30GS		2SFX30GZ	
Volume	3.0 GPM	(11.0 L/M)	3.0 GPM	(11.0 L/M)
Max. Discharge Pressure	2000 PSI	(140 BAR)	2500 PSI	(175 BAR)
Max. RPM	3450 RPM	(3450 RPM)	3450 RPM	(3450 RPM)
Stroke.....	0.185"	(4.7 mm)	0.185"	(4.7 mm)

Optional Electric-3/4" Shaft - 2SFX30GES

MODEL	2SFX35GS			
Volume	3.5 GPM		(13.0 L/M)	
Max. Discharge Pressure	2000 PSI		(140 BAR)	
Max. RPM.....	3450 RPM		(3450 RPM)	
Stroke	0.220"		(5.6 mm)	

Optional Electric-3/4" Shaft - 2SFX35GES

"Customer confidence is our greatest asset"

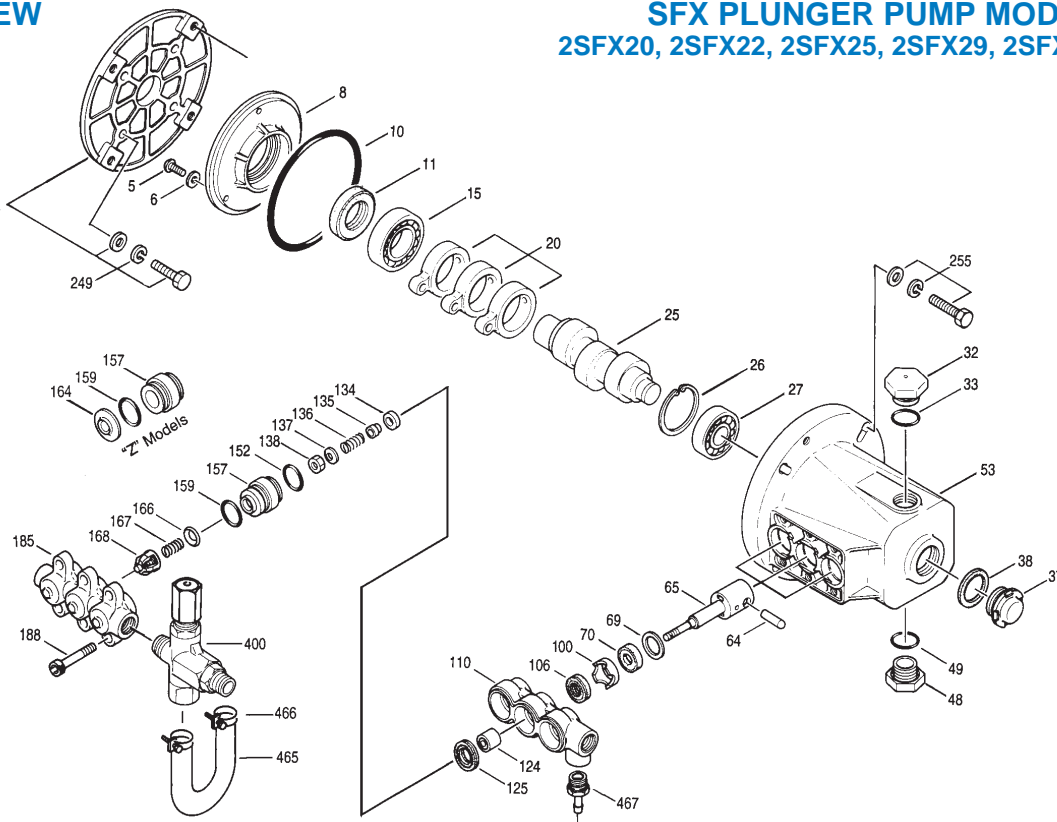

PARTS LIST

ITEM	P/N	MATL	DESCRIPTION	MODEL USED	QTY	ITEM	P/N	MATL	DESCRIPTION	MODEL USED	QTY
5	89551	STZP	Screw, HHC (M6x16)	All Models	3	135	44871	S	Spacer	All Models	3
6	150810	NBR	Washer, Seal (M6)	All Models	3	136	44872	S	Spring, Inlet Valve	All Models	3
8	44857	AL	Cover, Bearing, Inner	All Models	1	137	88575	S	Washer, Conical (M6)	All Models	3
10	14044	NBR	O-Ring, Bearing Cover	All Models	1	138	81240	SS	Nut, Hex (M6)	All Models	3
11	44859	NBR	Seal, Oil	All Models	1	152	26089	NBR	O-Ring, Adapter - 80	All Models	3
15	14488	STL	Bearing, Ball, Inner	All Models	1	<i>11377</i>	<i>FPM</i>	<i>O-Ring, Adapter</i>	<i>All Models</i>	<i>3</i>	
20	45876	HS	Rod, Connecting	All Models	3	157	45859	BB	Adapter, Discharge, Seat	All Models	3
	542951	BZ	Rod, Connecting	2SFX25GZ,30GZ	3	45923	BB	Adapter, Discharge, Seat	2SFX29EL	3	
25	45092	FCM	Crankshaft, 3450 RPM, 5/8", 3.1mm	2SFX20ES	1	44878	BB	Spacer, Discharge, Valve	2SFX25GZ, 30GZ	3	
	44929	FCM	Crankshaft, 3450 RPM, 5/8", 3.35mm	2SFX22ES	1	159	26089	NBR	O-Ring, Adapter - 80	All Models	3
	44933	FCM	Crankshaft, 3450 RPM, 3/4", 3.35mm	2SFX22GS	1	<i>11377</i>	<i>FPM</i>	<i>O-Ring, Adapter</i>	<i>All Models</i>	<i>3</i>	
	45844	FCM	Crankshaft, 3450 RPM, 5/8", 3.8mm	2SFX25ES	1	164	44881	S	Seat	2SFX25GZ, 30GZ	3
	542967	FCM	Crankshaft, 3200 RPM , 3/4", 4.3mm	2SFX25GZ	1	166	43723	S	Valve	All Models	3
	45426	FCM	Crankshaft, 1725 RPM , 5/8", 8.5mm	2SFX29ELS	1	167	541062	S	Spring	All Models	3
	44931	FCM	Crankshaft, 3450 RPM, 5/8", 4.5mm	2SFX30ES	1	168	44565	PVDF	Retainer, Spring	All Models	3
	542441	FCM	Crankshaft, 3450 RPM, 3/4", 4.7mm	2SFX30GS,GZ	1	185	44879	BB	Manifold, Discharge	All Models	1
	45100	FCM	Crankshaft, 3450 RPM, 3/4", 5.6mm	2SFX35GS	1	188	87859	STZP	Screw, HSH (M8x75)	All Models	6
26	12385	STL	Ring, Retaining	All Models	1	249	30968		Kit, Adapter Mount, Gas	All Gas Models	1
27	15710	STL	Bearing, Ball, Outer	All Models	1	15845	STZP	Lockwasher, Split (M8)		4	
32	45690	RTP	Cap, Oil Filler	All Models	1	44843	STZP	Screw, HH (5/16-24)		4	
33	14179	NBR	O-Ring, Oil Filler Cap - 70	All Models	1	44942	AL	Flange, Adapter		1	
37	43987		Gauge, Bubble Oi	All Models	1	12489	STZP	Washer, Flat (M8)		4	
38	44428	NBR	Gasket, Flat Flex, Oil Gauge - 80	All Models	1	255	*30517	STZP	Kit, Bolt Mount	All Models	1
48	44842	NY	Plug, Drain (1/2" NPT)	All Models	1	30980	STZP	Washer, Flat (3/8")		4	
49	14179	NBR	O-Ring, Drain Plug - 70	All Models	1	30921	STZP	Lockwasher, Split (3/8")		4	
53*	541018	AL	Crankcase	All Models	1	34100	STZP	Screw, HH (3/8"-16x1-3/8")		4	
64	16948	S	Rist, Pin	All Models	3	6106		Lubricant, Antiseize		1	
65	540073	SZZ	Rod, Plunger, Unchromed	2SFX20,22,25,30,35	3	30050	STL	Key (3/16x3/16x1-1/4" HD)		1	
	540089	SZZ	Rod, Plunger, Unchromed	2SFX29ELS	3	300	34053	NBR	Kit, Seal (Incls: 106,125,152,159)	All Models	1
	542958	SHS	Rod, Plunger	2SFX25GZ,30GZ	3	33953		Kit, Seal, Hi-Temp (Incls: 106,125,134,152,159)	All Models	1	
69	20017	S	Washer (M24)	All Models	3	33453	FPM	Kit, Seal (Incls: 106,125,152,159)	All Models	1	
70	25461	NBR	Seal, Oil	All Models	3	310	34056	S	Kit, Valve (Incls: 152,157,159,166,167,168)	All except 29ELS,GZ	1
100	44869	PVDF	Retainer, Seal	All Models	3	34052	S	Kit, Valve (Incls: 152,159,164,166,167,168)	2SFX25GZ,30GZ	1	
106	44876	NBR	LPS w/S-Spg	All Models	3	311	34668		Kit, Inlet Valve (Incls: 134-138,152,159)	All Models	1
	103298	FPM	LPS w/S-Spg	All Models	3	352	44050	STZP	Gauge, Oil, Removal Tool	All Models	1
110	44874	BB	Manifold, Inlet	All Models	1	400	7500XS	BB	Unloader, Regulating	Std. 2SFX Models	1
124	45847	CC	Ceramic Plunger	All Models	3	467	45868	BB	Barb, Pump Inlet (1/4" Hose x 1/4" NPT)	All Models	1
	45429	CC	Ceramic Plunger	2SFX29ELS	3	—	7620	BB	Unloader, Regulating	2SFX25GZ, 30GZ	1
125	43245	NBR	HPS w/S PS	All Models	3	● —	34455	BB	Assembly, Pulsator	All Models	1
	46652	HT	HPS, Hi-Temp	All Models	3	—	6565.8		Service Video		1
134	45854	S	Valve, Inlet	All Models	3						
	33873	NY	Valve, Inlet, Hi-Temp	All Models	3						

● Industrial discount. *Italics are optional items.*

See Tech Bulletin 24, 43, 55, 65, 70, 73 and 74 for additional information.

* Effective with 1/90 Mfg. date 45853, 14036, 44861, 92519 have been replaced with new one piece crankcase.

Note: Discard Key which may come standard with most motors and engines and **use only the key included in this kit.**

MATERIAL CODES (Not Part of Part Number): AL=Aluminum BB=Brass BZ=Bronze CC=Ceramic FCM=Forged Chrome-moly HS=High Strength HT=Hi-Temp (EPDM Alternative) NBR=Medium Nitrile (Buna-N) NY=Nylon PVDF=Fluoroplastic (High Strength) RTP=Reinforced Composite S=304SS SHS=304SS/High Strength STL=Steel STZP=Steel/Zinc Plated SZZ=304SS/Zamak

Center raised pilot guide on the **Adapter Plate** assures proper alignment of pump and engine. Before mounting pump onto engine inspect engine for **recessed seal and bearing guide** to permit adapter to completely seat into recess and four bosses to be flush with engine face.

7500XS UNLOADER FOR "G, E, GS" PUMP MODELS

Specifications	U.S. Measure	Metric Measure
GPM.....	0.5-6.0 GPM	(2-23 L/M)
PSI.....	100-2000 PSI	(7-140 BAR)
Max. Temperature.....	190°F	(88°C)
Inlet port - Rear.....	3/8" NPT	(3/8" NPT)
Discharge Port - Front.....	3/8" NPT	(3/8" NPT)
By-pass Port - Barb.....	1/4" NPT	(1/4" NPT)
Weight.....	14 oz.	(0.40 kg)
Dimensions.....	3.0" x 1.0" x 4.25"	(76 x 25 x 108 mm)

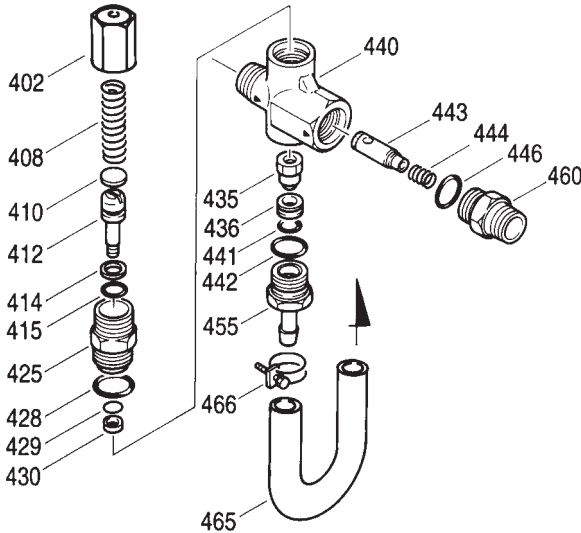

PARTS LIST

ITEM	P/N	MATL	DESCRIPTION	QTY
402	540081	BB	Cap, Hex Adjusting	1
404	31047	BB	Nut, Locking (Optional)	1
408	32094	STZP	Spring, Coil (2000 PSI)	1
410	107672	BB	Retainer, Spring	1
412	45694	S	Stem, Piston (M5)	1
414	20184	PTFE	Back-up-Ring	1
415	14190	NBR	O-Ring, Retainer	1
425	107673	BB	Retainer, Piston	1
428	13969	NBR	O-Ring - 70	1
429	14759	NBR	O-Ring, Body	1
430	107675	PTFE	Back-up-Ring, Body	1
435	45696	BB	Assembly, Valve and Ball (M5)	1
436	107680	S	Seat	1
440	—	BB	Body	1
441	13963	NBR	O-Ring, Valve	1
442	13969	NBR	O-Ring - 70	1
443	541060	BB	Valve, Check w/O-Ring	1
444	45924	S	Spring - 85 G	1
446	13969	NBR	O-Ring - 70	1
455	45865	BB	Barb, By-pass Fitting	1
460	107681	BB	Fitting, Discharge (3/8" NPT)	1
465	46140	—	By-pass Hose (5.5"x1/4")	1
	45983	—	By-pass Hose (9"x1/4") (Optional-UMS)	1
466	45929	STZP	Clamp, Hose	2
468	32097	NBR	Kit, O-Ring (Incls: 414,415,428,429,430,441,442,446)	1
485	7140	BB	Valve, Thermo (Optional)	1
	7135	RTP	Valve, Thermo (Optional)	1
486	34600	BB	Tee, T.V. Mount (Optional)	1
487	34576	BB	Nipple, T.V. Mount (Optional)	1

MATERIAL CODES (Not Part of Part Number):
 BB=Brass FPM=Fluorocarbon (Viton) NBR=Medium Nitrile (Buna-N)
 PTFE=Polytetrafluoroethylene (Teflon) RTP=Reinforced Composite
 S=304SS STZP=Steel/Zinc Plated

OPERATION

A Regulating Unloader comes with each 2SFX pump to provide system pressure regulation and pump protection.

For MAXIMUM SUCTION capability, Regulating Unloader should be remounted on discharge manifold, OPPOSITE from pump inlet port.

Standard Units return the by-pass back to the inlet of the pump and install a **Thermo Valve** in the by-pass line.

By-pass HOSE ASSEMBLY is designed for cold water or ambient temperature operation. DO NOT EXCEED 6 MINUTES in by-pass

7620 UNLOADER FOR "GZ" PUMP MODELS

Specifications	U.S. Measure	Metric Measure
GPM.....	0.5-7.8 GPM	(2-30 L/M)
PSI.....	100-3145 PSI	(7-220 BAR)
Max. Temperature.....	194°F	(90°C)
Inlet Port.....	3/8" BSPM	(3/8" BSPM)
Discharge Port.....	3/8" BSPF	(3/8" BSPF)
By-pass Port.....	3/8" BSPF	(3/8" BSPF)
Auxiliary Port.....	1/4" BSPF	(1/4" BSPF)
Weight.....	19.5 oz.	(0.55 kg)
Dimensions.....	3.2" x 1.5" x 4.7"	(81 x 38 x 119.4 mm)

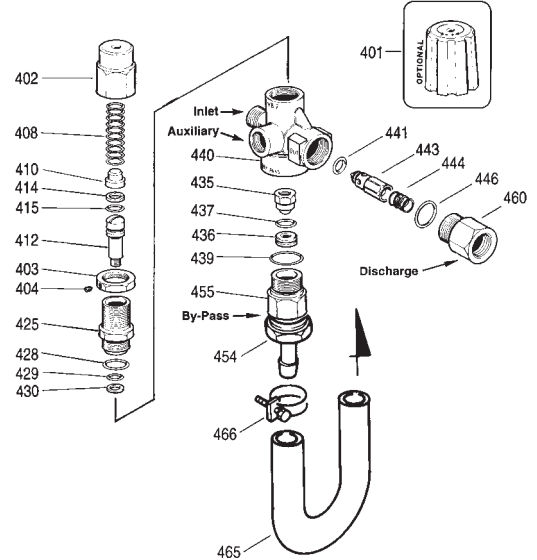

PARTS LIST

ITEM	P/N	MATL	DESCRIPTION	QTY
401	32088	NY	Cap, Black (Optional)	1
402	33859	BB	Cap, Hex Adjusting	1
403	33857	BB	Nut, Locking (M18x1)	1
404	33061	STZP	Screw, Set (M4x4)	1
408	32094	STZP	Spring, Coil (2000PSI)	1
410	32819	BB	Guide, Spring	1
412	33860	S	Stem, Valve	1
414	33278	PTFE	Back-up-Ring, Stem	1
415	—	NBR	O-Ring, Stem	1
425	33861	BB	Retainer, Piston	1
428	33043	NBR	O-Ring, Retainer	1
429	—	NBR	O-Ring, Stem	1
430	33276	PTFE	Back-up-Ring, Stem	1
435	33853	S	Assembly, Valve and Ball (M6)	1
436	33862	S	Seat	1
437	32008	FPM	O-Ring, Seat	1
439	33044	NBR	O-Ring, By-pass Fitting - 85	1
440	—	BB	Valve Body	1
441	32851	NBR	O-Ring, Flow Balancer	1
443	33852	BB	Valve, Check	1
444	33843	S	Spring, Flow Balancer	1
446	—	NBR	O-Ring, Discharge Fitting	1
454	33865	BB	Barb, By-pass (3/8" NPTx1/4)	1
455	33846	BB	Fitting, By-pass (3/8" NPT)	1
460	33847	BB	Fitting, Discharge (3/8" NPT)	1
465	45929	STZP	Hose (5.5"x1/4")	1
466	46140	—	Clamp, Hose	1
468	33098	NBR	Kit, O-Ring (Incls: 414,428,430,437,439,441)	1

MATERIAL CODES (Not Part of Part Number):
 BB=Brass FPM=Fluorocarbon (Viton) NBR=Medium Nitrile (Buna-N)
 NY=Nylon PTFE=Polytetrafluoroethylene (Teflon)
 S=304SS STZP=Steel/Zinc Plated

operation. Excessive temperatures will cause premature wear or damage to the pump and VOID THE WARRANTY.

Hi-Temp Units with special Hi-Temp seals do not use the by-pass hose back to the pump inlet or the Thermo Valve. Use optional Dual Pressure Switches and Mechanical Relay in Auto Shut Off Kits 34870 and 34871.

If unit is INFREQUENTLY USED OR PERIODICALLY STORED, seals may become dry. **UNDER SUCTION FEED, system must be PURGED BEFORE OPERATION** (system fluid must flow through the pump without discharge restriction) to assure full system pressure is reached.

MOTOR SPECIFICATIONS

Model 8050

Horsepower.....	1.5
Shaft Diameter.....	5/8"
Max. Volts.....	115
FULL LOAD AMPS.....	12.1
RPM.....	3450
Weight.....	48 lbs.
Phase.....	Single
Frame Size.....	56-C TEFC
Service Factor.....	1.15

★ Model 8052

Horsepower.....	2.0
Shaft Diameter.....	5/8"
Max. Volts.....	115/230
FULL LOAD AMPS.....	17.0/9.2-8.5
RPM.....	3450
Weight.....	43 lbs.
Phase.....	Single
Frame Size.....	56-C TEFC
Hertz.....	60
Service Factor.....	1.15

Model 8055

Horsepower.....	3.0
Shaft Diameter.....	● 3/4"
Max. Volts.....	208/230
FULL LOAD AMPS.....	15.2/13.6
RPM.....	3450
Weight.....	48 lbs.
Phase.....	Single
Frame Size.....	56-C TEFC
Service Factor.....	1.15

● Use 3/4" shaft size motor with GES Pumps.

Model 8057

Horsepower.....	5.0
Shaft Diameter.....	● 3/4"
Max. Volts.....	230
FULL LOAD AMPS.....	22.0
RPM.....	3450
Weight.....	48 lbs.
Phase.....	Single
Frame Size.....	56-C OPEN DRIP
Service Factor.....	1.15

● Use 3/4" shaft size motor with GES Pumps.

★ Model 8060

Horsepower.....	1.5
Shaft Diameter.....	5/8"
Max. Volts.....	115/208/230
FULL LOAD AMPS.....	14.0/7.0
RPM.....	1725
Weight.....	48.10 lbs.
Phase.....	Single
Frame Size.....	56-C TEFC
Service Factor.....	1.2

★ Model 8062

Horsepower.....	2.0
Shaft Diameter.....	5/8"
Max. Volts.....	115/230
FULL LOAD AMPS.....	17.0/8.5
RPM.....	1725
Weight.....	55 lbs.
Phase.....	Single
Frame Size.....	56-C TEFC
Service Factor.....	1.15

Common Motor Specifications

Max. Operating Temp.....	104°F
Hertz.....	60 Hz
Capacitor Start.....	Yes
Thermal Overload-Manual Reset	Yes
U.L. Construction Reference	
(8050,8055).....	E49747
(8052, 8057, 8060, 8062).....	E44549
U.L. Insulation Reference (All)....	E37878
CSA Reference	
(8050).....	LR45148
(8052, 8057, 8060, 8062).....	LR4642
(8055).....	LR2025

Note: Motor Start-Up AMPS may vary, then settle within FULL LOAD AMPS rating after initial run in time.

- ★ ★ Before mounting pump on motor, apply P.N. 6106 Antiseize Lubricant to pump shaft.
- ★ ★ Refer to Tech Bulletin #55 for instructions on removing pump from gas engine or electric motor.

For warranty consideration contact CAT PUMPS for the local **Authorized Service Center**. If you are uncertain as to the cause of failure (Pump or Motor), secure **Returned Goods Authorization number** and return complete assembly **PREPAID** to CAT PUMPS for evaluation.

HORSEPOWER REQUIREMENTS

E, GE, GES Flow		Pressure				Pump RPM
GPM	L/M	PSI 1000	PSI 1200	PSI 1500	PSI 2000	
		BAR 70	BAR 85	BAR 105	BAR 140	
2.2	8.3	1.5	1.8	2.3	3.0	3450
2.85	10.8	2.0	2.3	2.9	3.9	1725
3.0	11	2.1	2.5	3.1	4.2	3450
3.5	13	2.4	2.9	3.6	4.8	3450
GZ Flow		PSI 1200	PSI 1500	PSI 2000	PSI 2500	Pump RPM
		BAR 85	BAR 105	BAR 140	BAR 175	
2.5	9.5	2.1	2.6	3.4	4.3	3200
3.0	11	2.5	3.1	4.2	5.2	3450

DETERMINING THE REQUIRED H.P.

$$\frac{\text{GPM} \times \text{PSI}}{1460} = \text{Electric Brake H.P. Required}$$

MOTORIZED PUMPING UNITS

Model.....	2SFX20ESD 2SFX22ESD	2SFX22ESD.2	2SFX29ELSD	2SFX30GESD.3 2SFX35GESD.3
Weight.....	46.0 lbs.	48.6 lbs.	56.6 lbs.	51.6 lbs.
Dimensions				
Length.....	18.21"	19.21"	19.21"	20.71"
Width.....	7.36"	7.36"	7.36"	7.36"
Height.....	9.14"	9.14"	9.14"	9.14"

DIMENSIONAL DRAWING

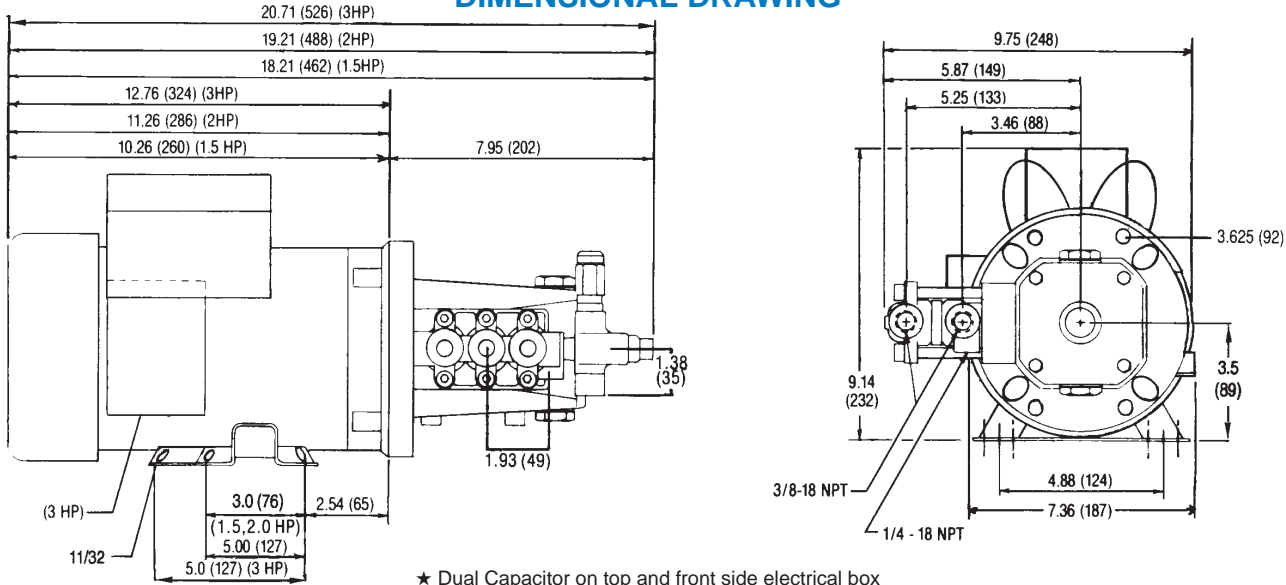

Products described hereon are covered by one or more of the following U.S. patents 3558244, 3652188, 3809508, 3920356, 3930756 and 5035580

Feb 1998 1891

World Headquarters

CAT PUMPS

1681 - 94th Lane N.E. Minneapolis, MN 55449-4324

Phone (612) 780-5440 — FAX (612) 780-2958

e-mail: sales@catpumps.com

www.catpumps.com

International Inquiries

FAX (612) 785-4443

e-mail: intlsales@catpumps.com



The Pump with "Nine Lives"

CAT PUMPS (U.K.) LTD.

1 Fleet Business Park, Sandy Lane, Church Crookham, Fleet

Hampshire GU13 0BF, England

Phone Fleet 44 1252-622031 — Fax 44 1252-626655

N.V. CAT PUMPS INTERNATIONAL S.A.

Heiveldekens 6A, 2550 Kontich, Belgium

Phone 32-3-450.71.50 — Fax 32-3-450.71.51

e-mail: cpi@catpumps.be

CAT PUMPS DEUTSCHLAND GmbH

Buchwiese 2, D-65510 Idstein, Germany

Phone 49 6126-93030 — Fax 49 6126-930333

e-mail: catpumps@t-online.de