

Dual Groove
(pump sold separately)

Single Groove
(pump sold separately)

FEATURES

- Special e-coating offers 3 to 6 times better corrosion resistant finish.
- Special bearings with unique grease offer more consistent viscosity at high temperatures and better water resistance for harsh environments.
- Special projection welded coil and plate offers extra durability in heavy vibration applications.
- Superior strength forged rotor, hub and armature offer superior flux and maximum torque for long life.

SELECTION: Select the clutch to match the pump shaft size and belt horsepower rating. Single and double groove are available for increased horsepower requirements. The clutch is very easy to install.

INSTALLATION:

1. Remove the four bearing cover screws on pump and discard.
2. Line up the clutch plate with the bearing cover screw holes with the **dish side out**. Secure with four flanged centering screws (M6-3CP, 3FR, 3PFR, 4FR, 5FR, 5PFR) (M8-5CP) and torque per specifications.
3. Mount the coil assembly onto the clutch plate and secure with four flanged centering screws (1/4"-20x3/8"). **Do not use pump bearing cover screws.**
4. Lubricate the pump shaft with antiseize lubricant and insert the key into the pump shaft.
5. Slide the rotor and armature assembly over shaft. Be certain keyway of pump is aligned with armature keyway. Secure with flat washer and shaft screw (M8x25) and torque to specifications.
6. Connect the lead wire to the positive side of the electric circuit. Also be certain there is an adequate grounded connection to the coil assembly plate.
7. Engage and disengage the clutch to assure proper functioning. If full load is required initially from the pump, allow clutch to engage 20-50 cycles before commencing normal operation for adequate burnishing.

NOTE: Follow standard belt mounting and center distance procedures to determine drive pulley size, speed and horsepower per belt.

Industrial Clutches

Models 34961, 34964
3FR and 4FR Piston Pumps
3PFR Plunger Pumps

Models 34960, 34965
3CP Plunger Pumps

Models 34962, 34963
5FR Piston and 5PFR Plunger Pumps

Models 34970, 34980
5CP Plunger Pumps

SPECIFICATIONS

MODELS	34961	34964
Pump Model	3FR, 3PFR, 4FR	3FR, 3PFR, 4FR
Clutch Grooves	1	2
Shaft Size.....	16.5 mm	16.5 mm

MODELS	34960	34965
Pump Model	3CP	3CP
Clutch Grooves	1	2
Shaft Size.....	16.5 mm	16.5 mm

MODELS	34962	34963
Pump Model	5FR, 5PFR	5FR, 5PFR
Clutch Grooves	1	2
Shaft Size.....	20 mm	20 mm

MODELS	34970	34980
Pump Model	5CP	5CP
Clutch Grooves	1	2
Shaft Size.....	20 mm	20 mm

COMMON SPECIFICATIONS

	U.S. Measure	Metric Measure
Diameter	7"	(7")
Belt Type	A	(A)
Torque.....	75 ft./lbs.	(101.7 Nm)
Watts	44	(44)
Amps	3.6	(3.6)
Power Required	12 VDC	(12 VDC)
Weight.....	8.6 lbs.	(3.9 kg)
Dimensions	7.0" x 2.07"	(177.8 x 52.6 mm)

OPERATION: The clutch works with a flow switch, pressure switch or a manual on/off switch installed in the system and connected to a 12VDC power supply. When the trigger gun is released or the unit is manually turned off, a signal is sent to the clutch to disengage and cease pump operation. When operation resumes by opening the trigger gun or manually turning the system on, the clutch will engage, starting the pump and resuming full operation.

“Customer confidence is our greatest asset”

EXPLODED VIEW

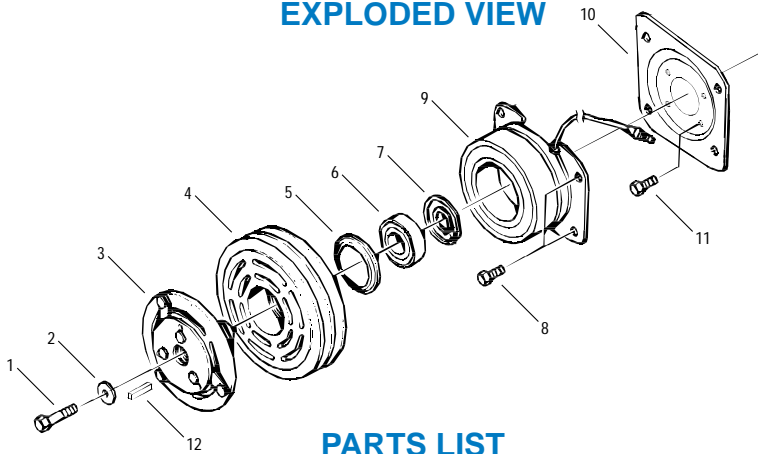

PARTS LIST

ITEM	DESCRIPTION		MODEL NUMBER							QTY	
		MATL	34960	34961	34962	34963	34964	34965	34970	34980	
1	Screw, Shaft, HH (M8x25)	STZP	92530	92530	92530	92530	92530	92530	92530	92530	1
2	Washer, Retaining Bolt	STZP	—	—	26118	26118	—	—	26118	26118	1
3	Armature	—	—	—	—	—	—	—	—	—	1
4	Rotor	—	—	—	—	—	—	—	—	—	1
5	Seal	—	—	—	—	—	—	—	—	—	1
6	Bearing	—	—	—	—	—	—	—	—	—	1
7	Ring, Snap	—	—	—	—	—	—	—	—	—	1
8	Screw, Coil Assembly	STZP	—	—	—	—	—	—	—	—	4
9	Assembly, Coil	—	—	—	—	—	—	—	—	—	1
10	Plate, Clutch	STZP	34932	34946	34948	34948	34946	34932	34933	34933	1
11	Screw	STZP	34934	34934	34934	34934	34934	34934	34935	34935	4
12	Key	STL	30089	30089	30057	30057	30089	30089	30057	30057	1
—	Lubricant, Antiseize	—	6106	6106	6106	6106	6106	6106	6106	6106	1

Material Codes (Not Part of Part No.): STL=Steel STZP=Steel/Zinc Plated Note: Add C1 (single) or C2 (dual) to standard pump model for ordering pump and clutch assembly.

TORQUE REQUIREMENTS

Item	Thread Size	Tool Size	in.lbs.	ft.lbs.	Nm
Plate Screws (3CP, 3FR, 3PFR, 4FR, 5FR, 5PFR)	M6	M8 Hex	55	4.4	6.2
Plate Screws (5CP)	M8	M10 Hex	115	9.4	13
Coil Assembly Screws	1/4"	3/8" Hex	55	4.4	6.2
Shaft Screw	M8	M13 Hex	115	9.4	13

TROUBLESHOOTING

- | | |
|---|---|
| Clutch will not engage | <ul style="list-style-type: none"> • Check positive and ground connections. • Check for 12 VDC. |
| Squealing belt(s) | <ul style="list-style-type: none"> • Check belt slippage or belt tension. |
| Short belt life | <ul style="list-style-type: none"> • Check side-to-side alignment and belt tension. • Undersized belts; upgrade to dual clutch. |
| Excessive noise when clutch disengaged | <ul style="list-style-type: none"> • Worn bearing; replace clutch assembly. |
| Clutch cycling | <ul style="list-style-type: none"> • Check for adequate voltage. • Worn rotor or discolored rotor surface; replace clutch assembly. |
| Scraping noise when clutch engaged and/or disengaged. | <ul style="list-style-type: none"> • Check alignment of coil and rotor assembly. |

DIMENSIONAL

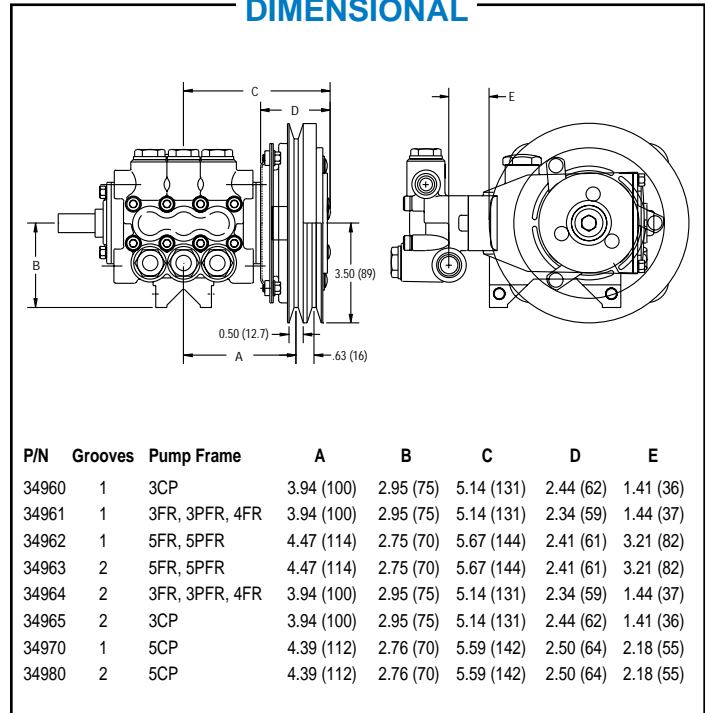

Products described hereon are covered by one or more of the following U.S. patents 3558244, 3652188, 3809508, 3920356, 3930756 and 5035580

Oct 1999 7968

World Headquarters

CAT PUMPS

1681 - 94th Lane N.E. Minneapolis, MN 55449-4324

Phone (612) 780-5440 — FAX (612) 780-2958

e-mail: sales@catpumps.com

www.catpumps.com

International Inquiries

FAX (612) 785-4329

e-mail: intlsales@catpumps.com



"The World's Longest Lasting Pumps"

CAT PUMPS (U.K.) LTD.

1 Fleet Business Park, Sandy Lane, Church Crookham, Fleet

Hampshire GU13 0BF, England

Phone Fleet 44 1252-622031 — Fax 44 1252-626655

N.V. CAT PUMPS INTERNATIONAL S.A.

Heiveldkens 6A, 2550 Kontich, Belgium

Phone 32-3-450.71.50 — Fax 32-3-450.71.51

e-mail: cpi@catpumps.be www.catpumps.be

CAT PUMPS DEUTSCHLAND GmbH

Buchwiese 2, D-65510 Idstein, Germany

Phone 49 6126-93030 — Fax 49 6126-930333

e-mail: catpumps@t-online.de www.catpumps.de