



Stainless Steel Pressure Regulator

Models 7061
 7063
 7073
 7095, 7096

FEATURES

- Maintains full system pressure while running in idle.
- Offers pump protection against pressure fluctuations and system changes.
- Minimum pressure fluctuations with the alternating use of multiple guns and nozzles.
- Top adjusting knob and locking nut to secure exact pressure setting.
- No external moving parts. Stainless Steel and Viton® internal parts for temperature and fluid compatibility.

SPECIFICATIONS

	U.S. Measure	Metric Measure
MODEL 7061		
Flow Range	10-70 GPM	(38-265 L/M)
Pressure Range	400-1000 PSI	(30-70 BAR)
MODEL 7063		
Flow Range	10-70 GPM	(38-265 L/M)
Pressure Range	600-1800 PSI	(45-125 BAR)
MODEL 7073		
Flow Range	10-70 GPM	(38-265 L/M)
Pressure Range	1200-2000 PSI	(85-140 BAR)
MODEL 7095		
Flow Range	10-75 GPM	(38-284 L/M)
Pressure Range	400-1000 PSI	(30-70 BAR)
MODEL 7096		
Flow Range	10-75 GPM	(38-284 L/M)
Pressure Range	1000-2000 PSI	(70-140 BAR)
COMMON SPECIFICATIONS		
Max. Temperature	180°F	(82°C)
Inlet Port	1" NPTF	(1" NPTF)
By-Pass Port	1-1/4" NPTF	(1-1/4" NPTF)
Weight	6.2 lbs.	(2.8 kg)
Dimensions	9.1" x 3.43" x 2.38"	(231x87x60.45 mm)

“Customer confidence is our greatest asset”

SELECTION: This **Pressure Regulator** is designed for systems with **single or multiple** pumps, solenoid (gate) valves, nozzles, standard or “weep” guns.

This regulator maintains established system pressure even when only one of several guns (nozzles) or solenoid (gate) valves is open or a nozzle is clogged, by-passing the unrequired flow.

It returns to established system pressure without delay upon squeezing the trigger gun(s) or opening the solenoid (gate) valve(s).

Select the specific model of regulator to meet both the desired system flow (combined nozzle flow rate requirement) and the desired system pressure.

Exercise caution when matching the system requirements to the regulator flow capacity and pressure rating. Operation below the minimum flow of the regulator causes the regulator to cycle or chatter. Operation beyond the rated regulator flow causes premature valve wear, regulator cycling and prevents attaining desired system pressure.

Select a high pressure nozzle sized to provide for both the desired **system flow** and pressure and **regulator by-pass**.

CAUTION

A MINIMUM BY-PASS FLOW of 10% of the REGULATOR RATED FLOW CAPACITY is required for proper regulator performance.

When properly set this regulator protects the pump from pressure extremes associated with obstructions in the discharge line, while maintaining the established system pressure. When no flow is required by the system, the regulator by-passes all the system flow, but holds system pressure in the discharge line [between the regulator and gun(s) or solenoid valve(s)] **and at the pump** head ready for a quick return to high pressure operation.

INSTALLATION: This regulator operates properly when mounted in any direction, however, it is preferred to keep the plumbing to a minimum and the adjustment knob easily accessible. The best location is directly on the pump discharge manifold head. Plumbing to and from the regulator should be at least the size of the regulator ports and flexible, high pressure hose (minimum single wire braid) is required.

The standard **inlet connection** of this regulator is located at the **side**. The regulator can be mounted directly onto the discharge manifold head or “teed” into the discharge line.

The **by-pass connection** is on the **bottom** of the regulator and can be plumbed in one of the following methods. Note that prolonged by-pass can result in significant heat build-up and frequent by-pass can result in premature wear to the valve. A **MINIMUM BY-PASS OF 10%** is necessary for the regulator to operate properly.

CAUTION

If the entire output is directed through the regulator (zero by-pass) the “cushioning” feature of the by-pass fluid is eliminated and the regulator can malfunction or wear prematurely.

Check the amount of by-pass by disconnecting the by-pass line and measuring the flow into a graduated container.

By-Pass to Reservoir: Ideally the by-pass line should be directed to a reservoir with at least one baffle between the supply line to the pump (from the reservoir) and the return by-pass line (from the regulator into the reservoir). This baffle minimizes turbulence and air bubbles that could enter the pump inlet feed line. **The reservoir capacity should be 6 to 10 times the rated system flow per minute.**

By-Pass to Pump Inlet: Although not recommended, by-pass fluid can be returned to the inlet line of the pump or directly to a pump inlet port (**systems up to 10 GPM**). When using this method an *Inlet Pressure Regulator* should be installed on the inlet line to avoid excessive inlet pressure. Be certain the *Inlet Pressure Regulator* is **between** the pump inlet and the by-pass line connection. When using this method, a *Thermo Valve* should be installed in the by-pass line to protect the pump from temperature build-up and premature seal failure.

The by-pass line should be **connected to the pump inlet line at a gentle angle of 45° or less and no closer than 10 times the pump inlet port diameter** e.g. 1-1/2" port size = 15" distance from pump inlet port. **Refer to Technical Bulletin 064 for additional information on the size and length of the by-pass line.**

By-Pass to Drain: If the by-pass is limited and infrequent, the by-pass can easily drain to an unpressurized drain line (to the ground).

TYPICAL INSTALLATION

Piston Pump

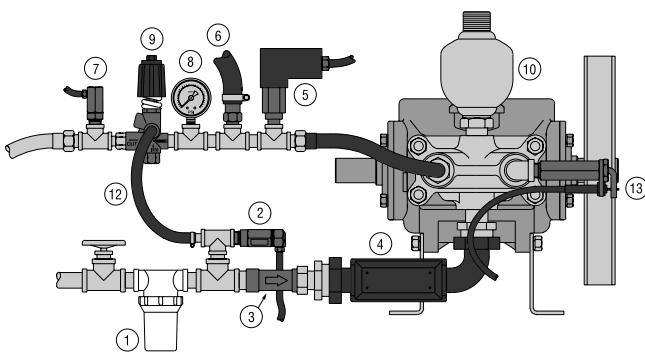

Plunger Pump

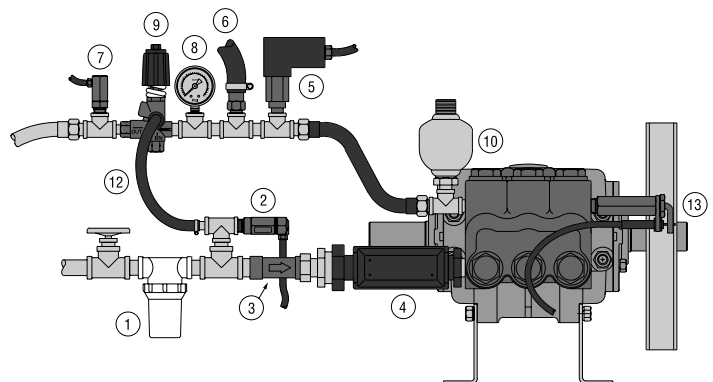

It is recommended that a secondary protective device such as the *CAT PUMP Pop-Off Valve* be installed to assure pump protection should the regulator malfunction. Refer to Troubleshooting for more information on malfunction of regulator.

Preferred mounting of the *Prrrrr-o-lator* (pulsation dampener) is directly **on the Discharge Manifold Head**. When using the *Inlet Pressure Regulator*, mount the *Prrrrr-o-lator* **downstream from the regulator** to assure optimum performance of the regulator.

CAUTION

Oversizing the *Prrrrr-o-lator* may cause delayed response from the regulator.

PRESSURE ADJUSTMENT AS A REGULATOR: Setting and adjusting the regulator pressure must be done with the system “on”. Start the system with the regulator backed off to the **lowest pressure** setting. Squeeze the trigger and read the pressure on the gauge at the pump. If more pressure is desired, release the trigger, turn adjustment knob one quarter turn, squeeze the trigger and read the pressure. Repeat this process until desired pressure is attained. Pressure fluctuation from this established system pressure is minimal with the opening of each additional gun.

Monitor the by-pass flow at each adjustment. If the by-pass flow, with all guns or valves open, drops below 10% of rated regulator flow, STOP ADJUSTMENT. The nozzle(s) selection is improperly sized to achieve the desired system pressure.

Proceed by accepting the attained pressure OR selecting a smaller or fewer nozzles OR increasing the pump RPM providing you stay within specifications OR selecting a larger pump or dual pumps.

Once the desired system pressure is reached, stop adjusting and set the top locking knob to hold the system pressure. **Do not read the pressure at the gun or nozzle for setting system pressure.** Check the nozzle(s) as part of regular maintenance and replace if worn. **Do not adjust regulator pressure setting to compensate for worn nozzle(s).**

PRESSURE ADJUSTMENT AS A RELIEF VALVE: When the regulator is used as a secondary relief valve, adjust the pressure of the relief valve in the same increments as the primary valve is being set, then adjust the relief valve to approximately 200 PSI above the primary valve pressure setting.

Approximate Pressure Reading at Gauge	Gauge Between Pump/Regulator	Gauge Between Regulator/Gun-Nozz-Valve
System in operation (gun open)	system pressure	system pressure
System in by-pass (all guns, valves closed)	system pressure	system pressure

TROUBLESHOOTING

Cycling/Chattering	<ul style="list-style-type: none"> ● Too little flow for valve specifications. ● Air in system, poor connections. ● Inlet seals in pump worn. ● O-ring in gun worn.
System will not build up to pressure	<ul style="list-style-type: none"> ● Nozzle worn. ● Improper nozzle size for system specs.
Pressure drop	<ul style="list-style-type: none"> ● Nozzles worn. ● Piston and seat in regulator worn. ● Air in system, poor connections. ● Insufficient flow to pump. ● Filter clogged. Check and clean regularly.
Pressure spikes while in by-pass	<ul style="list-style-type: none"> ● Minimum by-pass of 10% not present. ● Excessive pressure adjustment made for worn nozzle. REPLACE NOZZLE. Reset system pressure.
Leakage from regulator vent hole	<ul style="list-style-type: none"> ● O-ring around piston worn. Replace. ● Piston Retainer scored. Replace.

WARRANTY

90 Day Warranty
Refer to complete Cat Pump Warranty for further information.

- | | |
|---|-------------------------------|
| 1 Inlet Filter | 7 Quick Start Valve |
| 2 Thermo Valve | 8 Pressure Gauge |
| 3 Inlet Pressure Regulator | 9 Pressure Regulator/Unloader |
| 4 C. A.T. Tube
(Captive Acceleration Tube) | 10 Pulsation Dampener★ |
| 5 Pressure Switch | 11 Chemical Injector |
| 6 Pop-Off Valve | 12 By-pass Hose |
| | 13 Throttle Controller |

★ Preferred mounting of Pulsation Dampener [Prrrrr-O-Lator] is directly on the discharge manifold of the pump. The preferred mounting of the by-pass hose [when returning to the inlet] is before the Pressure Reducing Valve. If this is not possible, then mount the Prrrrr-O-Lator after the Pressure Unloading Valve to prevent pressure spikes to the pump inlet.

These illustrations show the basic elements for a typical installation of a high pressure piston or plunger pump. **Not all components shown are required for all applications or systems.** Each component presents potential problems that too often are ascribed to a perfectly functioning pump, such as: a clogged strainer, a partially closed shut-off valve, a faulty gauge, or a malfunctioning regulator/unloader. Proper system installation, routine lubrication, monitoring and maintenance of components are your basic guarantees of optimum pump performance. CAT PUMPS does not assume any liability or responsibility for the design or operation of a customer’s high pressure system.

EXPLODED VIEW

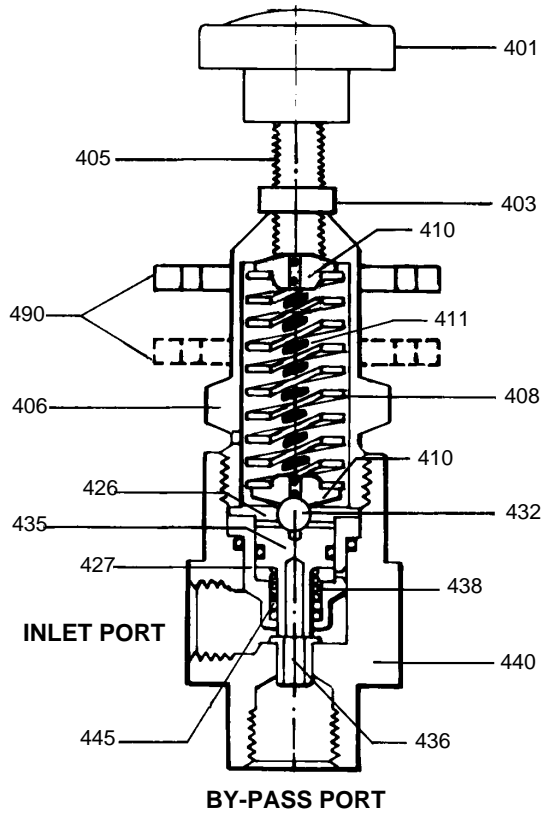

CUTAWAY

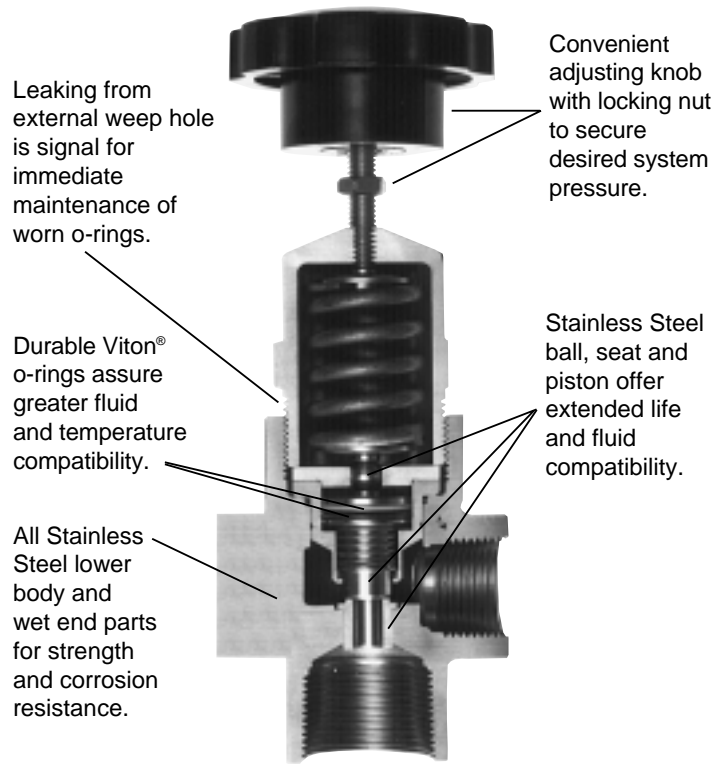

PARTS LIST

ITEM	DESCRIPTION	MODEL NUMBER										QTY
		7061	MATL	7063	MATL	7073	MATL	7095	MATL	7096	MATL	
401	Knob, Adjusting	30948	NY	30948	NY	30948	NY	30948	NY	30948	NY	1
403	Nut, Lock	30933	S	30933	S	30933	S	30933	S	30933	S	1
405	Screw, Adjusting	30932	S	30932	S	30932	S	30932	S	30932	S	1
406	Body, Upper	30928	BBNP	30928	BBNP	30928	BBNP	30928	BBNP	30928	BBNP	1
408	Spring	30935	S	30946	S	30946	S	30935	S	30946	S	1
410	Retainer, Spring	30931	BB	30931	BB	34289	BB	30931	BB	30931	BB	2
411	Spring, Inner	—	—	—	—	34296	S	—	—	—	—	1
426	Guide	30927	BB	30927	BB	30927	BB	30927	BB	30927	BB	1
427	Insert	30926	SS	30926	SS	30926	SS	30926	SS	30926	SS	1
432	Ball	30936	SS	30936	SS	30936	SS	30936	SS	30936	SS	1
435	Piston	30924	SS	30924	SS	30924	SS	34171	SSSS	34292	SSSS	1
436	Seat	30918	S	30918	S	30918	S	34190	SSSS	34297	SSSS	1
438	Spring, Seat	30934	S	30934	S	30934	S	30934	S	30934	S	1
440	Body, Lower (Hex)	33917	SS	33917	SS	33917	SS	33917	SS	33917	SS	1
445	Washer	30925	SS	30925	SS	30925	SS	30925	SS	30925	SS	1
468	Kit, O-Ring	30950	FPM	30950	FPM	30950	FPM	30950	FPM	30950	FPM	1
490	Bracket, Panel Mount	30947	STL	30947	STL	30947	STL	30947	STL	30947	STL	1

Italics are optional items.

MATERIAL CODES (Not Part of Part Number): BB=Brass BBNP=Brass/Nickel Plated FPM=Fluorocarbon (Viton®)

NY=Nylon S=304SS SS=316SS SSSS=440SS STL=Steel

Products described hereon are covered by one or more of the following U.S. patents 3558244, 3652188, 3809508, 3920356, 3930756 and 5035580

Apr 1999 4915

World Headquarters

CAT PUMPS

1681 - 94th Lane N.E. Minneapolis, MN 55449-4324

Phone (612) 780-5440 — FAX (612) 780-2958

e-mail: sales@catpumps.com

www.catpumps.com

International Inquiries

FAX (612) 785-4443

e-mail: intlsales@catpumps.com



The Pump with "Nine Lives"

CAT PUMPS (U.K.) LTD.

1 Fleet Business Park, Sandy Lane, Church Crookham, Fleet

Hampshire GU13 0BF, England

Phone Fleet 44 1252-622031 — Fax 44 1252-626655

N.V. CAT PUMPS INTERNATIONAL S.A.

Heiveldekens 6A, 2550 Kontich, Belgium

Phone 32-3-450.71.50 — Fax 32-3-450.71.51

e-mail: cpi@catpumps.be

CAT PUMPS DEUTSCHLAND GmbH

Buchwiese 2, D-65510 Idstein, Germany

Phone 49 6126-93030 — Fax 49 6126-930333

e-mail: catpumps@t-online.de