



Pressure Sensitive Pressure Regulator

Model **7080**
 7082

FEATURES

- Provides system pressure setting and protection for single or multiple gun and pump systems.
- Compact size and easy installation.
- Immediately returns to system pressure when gun opens.
- Springs are color coded for easy valve identification and simple change from one pressure rating to another.

SPECIFICATIONS

	U.S. Measure	Metric Measure
MODEL 7080		
Flow Range	2.5-7.8 GPM	(9-34 L/M)
Pressure Range	150-1450 PSI	(10-100 BAR)
Inlet Port	3/8" NPTF	(3/8" NPTF)
Outlet Port	3/8" NPTF	(3/8" NPTF)
By-Pass Port	3/8" NPTF	(3/8" NPTF)
Maximum Temperature	160°F	(71°C)
Weight	1.0 lbs.	(0.49 Kg)
Dimensions	3.1 x 2.0 x 6.4"	(78 x 51 x 163 mm)
MODEL 7082		
Flow Range	2.5-7.8 GPM	(9-34 L/M)
Pressure Range	850-3575 PSI	(60-245 BAR)
Inlet Port	3/8" NPTF	(3/8" NPTF)
Outlet Port	3/8" NPTF	(3/8" NPTF)
By-Pass Port	3/8" NPTF	(3/8" NPTF)
Maximum Temperature	160°F	(71°C)
Weight	1.0 lbs.	(0.49 Kg)
Dimensions	3.1 x 2.0 x 6.4"	(78 x 51 x 163 mm)

“Customer confidence is our greatest asset”

SELECTION: This **pressure regulator** is designed for systems with **single or multiple** pumps, solenoid (gate) valves, nozzles, and standard or “weep” guns.

This regulator holds established system pressure in the discharge line when the trigger gun is closed or solenoid (gate) valve is closed or the nozzle is clogged, by-passing the unrequired flow. It returns to established system pressure without delay upon squeezing the trigger gun or opening the solenoid (gate) valve(s).

Select the specific model of regulator to meet both the desired system flow (combined nozzle flow rate requirement) and the desired system pressure.

Exercise caution when matching the system requirements to the regulator flow capacity and pressure rating. Operation below the minimum flow of the regulator causes the regulator to cycle, or chatter. Operation beyond the rated regulator flow causes premature valve wear, regulator cycling and prevents attaining desired system pressure.

Select a high pressure nozzle sized to provide for both the desired **system flow** and pressure and **regulator by-pass**.

CAUTION

A MINIMUM BY-PASS FLOW of 10% of the REGULATOR RATED FLOW CAPACITY is required for proper regulator performance.

When properly set this regulator protects the pump from pressure extremes associated with obstructions in the discharge line, while maintaining the established system pressure. When no flow is required by the system, the regulator by-passes all the system flow. Pressure is held in the discharge line [between the pump and gun(s), solenoid valve(s) or nozzle(s)] ready for a quick return to high pressure operation.

INSTALLATION: This regulator operates properly when mounted in any direction, however, it is preferred to keep the plumbing to a minimum and the adjusting nut easily accessible. The best location is directly on the pump discharge manifold head. Plumbing to and from the regulator should be at least the size of the regulator ports and flexible, high pressure hose (minimum single wire braid) is required.

The standard **inlet connection** is at the **bottom**. The regulator should be mounted on the discharge manifold with the discharge line plumbed into the unloader discharge port to the front.

The **by-pass connection** is on the **side** of the regulator and can be plumbed in one of the following methods. Note that prolonged by-pass can result in significant heat build-up and frequent by-pass can result in premature wear to the valve. A **MINIMUM BY-PASS OF 10%** is necessary for the regulator to operate properly.

CAUTION

If the entire output is directed through the regulator (zero by-pass) the “cushioning” feature of the by-pass fluid is eliminated and the regulator can malfunction or wear prematurely.

Check the amount of by-pass by disconnecting the by-pass line and measuring the flow into a graduated container.

By-Pass to Reservoir: Ideally the by-pass line should be directed to a reservoir with at least one baffle between the supply line to the pump (from the reservoir) and the return by-pass line (from the regulator into the reservoir). This baffle minimizes turbulence and air bubbles that could enter the pump inlet feed line. **The reservoir capacity should be 10 times the rated system flow per minute.**

By-Pass to Pump Inlet: Although not recommended, by-pass fluid can be returned to the inlet line of the pump or directly to a pump inlet port (**systems up to 10 GPM**). When using this method an *Inlet Pressure Regulator* should be installed on the inlet line to avoid excessive inlet pressure. Be certain the Inlet Pressure Regulator is **between** the pump inlet and the by-pass line connection. When using this method, a *Thermo Valve* should be installed in the by-pass line to protect the pump from temperature build-up and premature seal failure.

The by-pass line should be **connected to the pump inlet line at a gentle angle of 45° or less and no closer than 10 times the pump inlet port diameter** e.g. 1-1/2" port size = 15" distance from pump inlet port. **Refer to Technical Bulletin 64 for additional information on the size and length of the by-pass line.**

By-Pass to Drain: If the by-pass is limited and infrequent, the by-pass can easily drain to an unpressurized drain line (to the ground).

TYPICAL INSTALLATION

Piston Pump

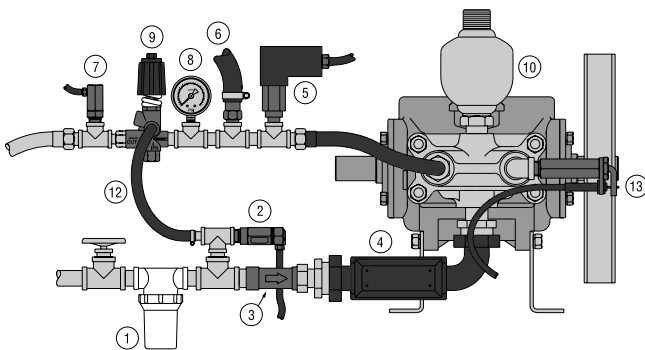

Plunger Pump

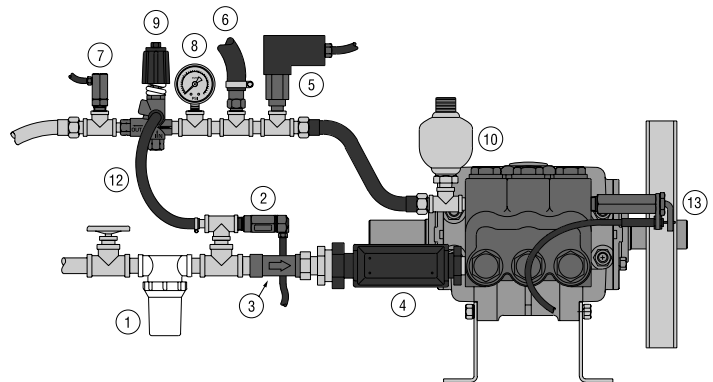

The **outlet connection** is located at the **front** of the regulator and marked with an arrow. Plumbing for the spray gun, nozzle or solenoid valve should be connected in from this discharge port.

It is recommended that a secondary protective device such as the *CAT PUMP Pop-Off Valve* be installed to assure pump protection should the regulator malfunction. Refer to Troubleshooting for more information on malfunction of regulator.

Preferred mounting of the *Prrrrr-o-lator* (pulsation dampener) is directly **on the Discharge Manifold Head**. When using an *Inlet Pressure Regulator*, mount the *Prrrrr-o-lator* **downstream from the regulator** to assure optimum performance of the regulator.

CAUTION

Oversizing the *Prrrrr-o-lator* may cause delayed response from the unloader.

PRESSURE ADJUSTMENT: Setting and adjusting the regulator pressure must be done with the system “on”. Start the system with the regulator backed off to the **lowest pressure** setting. Squeeze the trigger and read the pressure on the gauge at the pump. If more pressure is desired, release the trigger, turn adjusting nut one quarter turn, squeeze the trigger and read the pressure. Repeat this process until desired pressure is attained. Pressure fluctuation from this established system pressure is minimal with the opening of each additional gun.

Monitor the by-pass flow at each adjustment. If the by-pass flow, drops below 10% of rated regulator flow, STOP ADJUSTMENT. The nozzle selection is improperly sized to achieve the desired system pressure.

Proceed by accepting the attained pressure OR selecting a smaller or fewer nozzles OR increasing the pump RPM providing you stay within specifications OR selecting a larger pump or dual pumps.

Once the desired system pressure is reached, stop adjusting and set the top locking nut to hold the system pressure. **Do not read the pressure at the gun or nozzle for setting system pressure.** Check the nozzle(s) as part of regular maintenance and replace if worn. **Do not adjust regulator pressure setting to compensate for worn nozzle(s).**

Approximate Pressure Reading at Gauge	Gauge Between Pump/Unloader	Gauge Between Unloader/Gun-Nozzle-Valve
System in operation (gun open)	system pressure	system pressure
System in by-pass (gun closed)	system pressure	system pressure

TROUBLESHOOTING

Cycling/Chattering	<ul style="list-style-type: none"> ● Too little flow for valve specifications. ● Air in system, poor connections. ● Inlet seals in pump worn. ● O-ring in gun worn.
System will not build up to pressure	<ul style="list-style-type: none"> ● Nozzle worn. ● Improper nozzle size for system specs.
Pressure drop	<ul style="list-style-type: none"> ● Nozzles worn. ● Piston and seat in regulator worn. ● Air in system, poor connections. ● Insufficient flow to pump. ● Filter clogged. Check and clean regularly.
Pressure spikes while in by-pass	<ul style="list-style-type: none"> ● Minimum by-pass of 10% not present. ● Excessive pressure adjustment made for worn nozzle. REPLACE NOZZLE. Reset system pressure.
Leakage from regulator vent hole	<ul style="list-style-type: none"> ● O-ring around piston worn. Replace. ● Piston Retainer scored. Replace.

WARRANTY

90 Day Warranty

Refer to complete Cat Pump Warranty for further information.

- | | |
|---|-------------------------------|
| 1 Inlet Filter | 7 Quick Start Valve |
| 2 Thermo Valve | 8 Pressure Gauge |
| 3 Inlet Pressure Regulator | 9 Pressure Regulator/Unloader |
| 4 C. A.T. Tube
(Captive Acceleration Tube) | 10 Pulsation Dampener★ |
| 5 Pressure Switch | 11 Chemical Injector |
| 6 Pop-Off Valve | 12 By-pass Hose |
| | 13 Throttle Controller |

★ Preferred mounting of Pulsation Dampener [Prrrrr-O-Lator] is directly on the discharge manifold of the pump. The preferred mounting of the by-pass hose [when returning to the inlet] is before the Pressure Reducing Valve. If this is not possible, then mount the Prrrrr-O-Lator after the Pressure Unloading Valve to prevent pressure spikes to the pump inlet.

These illustrations show the basic elements for a typical installation of a high pressure piston or plunger pump. **Not all components shown are required for all applications or systems.** Each component presents potential problems that too often are ascribed to a perfectly functioning pump, such as: a clogged strainer, a partially closed shut-off valve, a faulty gauge, or a malfunctioning regulator/unloader. Proper system installation, routine lubrication, monitoring and maintenance of components are your basic guarantees of optimum pump performance. CAT PUMPS does not assume any liability or responsibility for the design or operation of a customer’s high pressure system.

EXPLODED VIEW

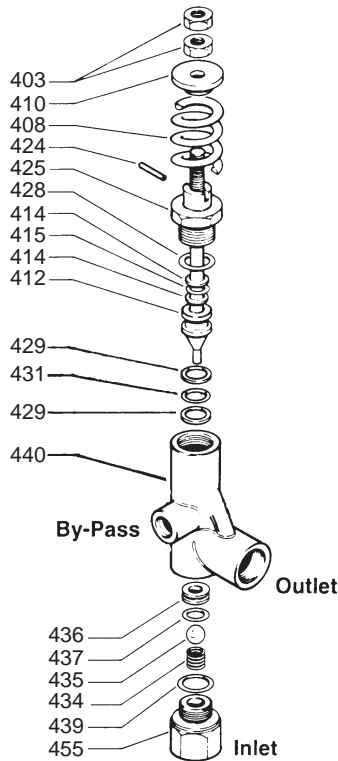

CUTAWAY

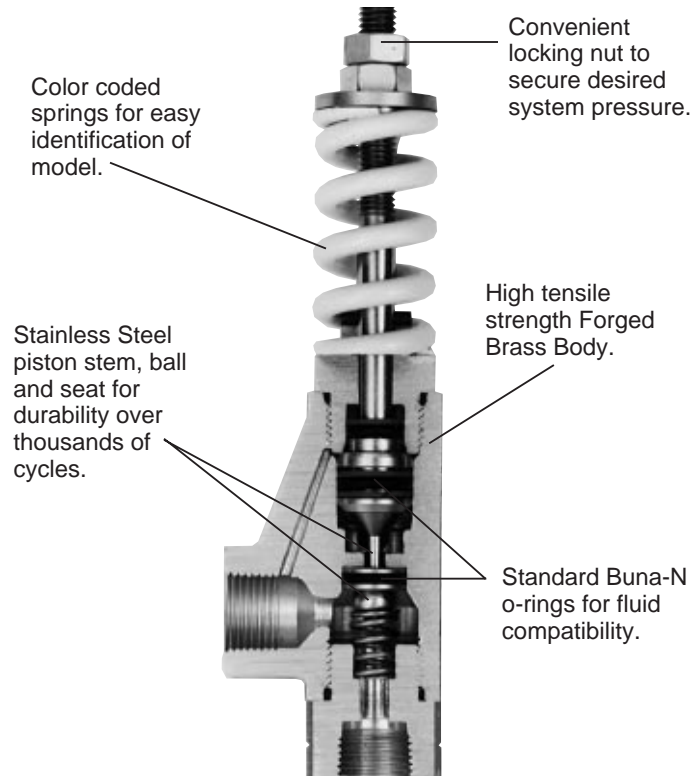

PARTS LIST

ITEM	DESCRIPTION	MODEL NUMBER		QTY
		7080 MATL	7082 MATL	
403	Nut, Adjusting (M8)	81109 STZP	81109 STZP	2
408	Spring, White (1450 PSI)	32090	—	1
	Spring, Blue (3450 PSI)	—	32092	1
410	Washer, Retaining	— BB	— BB	1
412	Stem-2, Piston	33219 S	33219 S	1
414	Back-up-Ring, Stem	32873 PTFE	32873 PTFE	2
415	O-Ring, Stem	33572 FPM	33572 FPM	1
424	Pin, Locking	32818 S	32818 S	1
425	Retainer, Hex Piston	33318 BB	33318 BB	1
428	O-Ring, Fitting	32113 NBR	32113 NBR	1
429	Back-up-Ring, Piston	33303 PTFE	33303 PTFE	2
431	O-Ring, Piston	32919 NBR	32919 NBR	1
	O-Ring, Piston	33575 FPM	33575 FPM	1
434	Spring	33781 STZP	33781 STZP	1
435	Ball	32289 S	32289 S	1
436	Seat	33640 S	33640 S	1
437	O-Ring, Seat	32008 NBR	32008 NBR	1
	O-Ring, Seat	33562 FPM	33562 FPM	1
439	O-Ring, Fitting	32113 NBR	32113 NBR	1
	O-Ring, Fitting	33567 FPM	33567 FPM	1
440	Body	— BB	— BB	1
447	Kit, Valve (Incls: 428,434,435,436,437)	33147 S	33147 S	1
455	Fitting, Inlet (3/8" NPTF)	32111 BB	32111 BB	1
468	Kit, O-Ring (Incls: 414,415,428,429,431,437,439) Prior to 6/88	33146 NBR	33146 NBR	1
—	★ Kit-2, O-Ring (Incls: 414,415,428,429,431,437,439) After 6/88	33246 NBR	33246 NBR	1
—	★ Kit-2, O-Ring (Incls: 414,415,428,429,431,437,439)	32878 FPM	32878 FPM	1

Italics are optional items.

MATERIAL CODES (Not Part of Part Number): BB=Brass FPM=Fluorocarbon (Viton®) NBR=Medium Nitrile (Buna-N)
PTFE=Polytetrafluoroethylene (Teflon®) S=304SS STZP=Steel/Zinc Plated

★ Changes effective with unloader marked "2" on body.

NOTE

Removing check valve assembly from 7570, 7572, 7573 and 7575 unloader will provide a similar version to this regulator/relief valve.

Products described hereon are covered by one or more of the following U.S. patents 3558244, 3652188, 3809508, 3920356, 3930756 and 5035580

Nov 1998 11802

World Headquarters

CAT PUMPS

1681 - 94th Lane N.E. Minneapolis, MN 55449-4324

Phone (612) 780-5440 — FAX (612) 780-2958

e-mail: sales@catpumps.com

www.catpumps.com

International Inquiries

FAX (612) 785-4443

e-mail: intlsales@catpumps.com



The Pump with "Nine Lives"

CAT PUMPS (U.K.) LTD.

1 Fleet Business Park, Sandy Lane, Church Crookham, Fleet

Hampshire GU13 0BF, England

Phone Fleet 44 1252-622031 — Fax 44 1252-626655

N.V. CAT PUMPS INTERNATIONAL S.A.

Heveldeken 6A, 2550 Kontich, Belgium

Phone 32-3-450.71.50 — Fax 32-3-450.71.51

e-mail: cpi@catpumps.be

CAT PUMPS DEUTSCHLAND GmbH

Buchwiese 2, D-65510 Idstein, Germany

Phone 49 6126-93030 — Fax 49 6126-930333

e-mail: catpumps@t-online.de